

## The Workplane button:

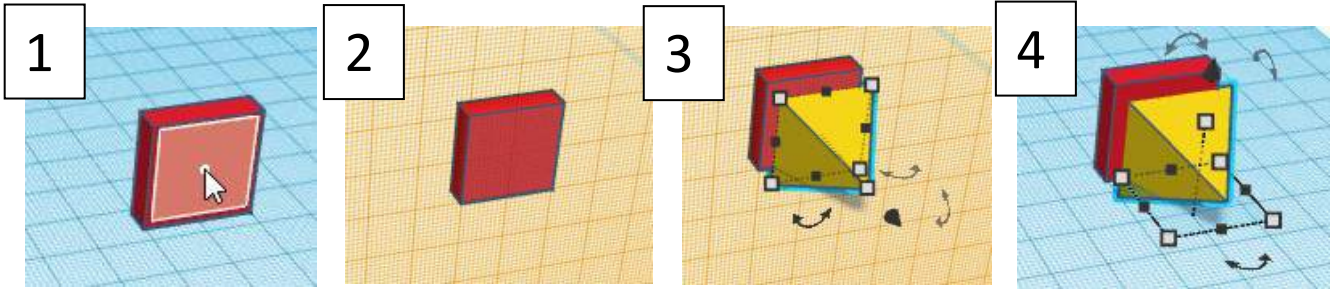

If you would like to work or build on the side of a shape, you can change the Workplane to be the surface of a shape side by clicking this button and then clicking the side of a shape.



## The Ruler button:



To use the ruler, click on the ruler button and then click where you would like the ruler to appear on the Workplane.

Once you have the ruler on the Workplane, you can select an object and then have the option to view the midpoint of the object selected or the endpoint.

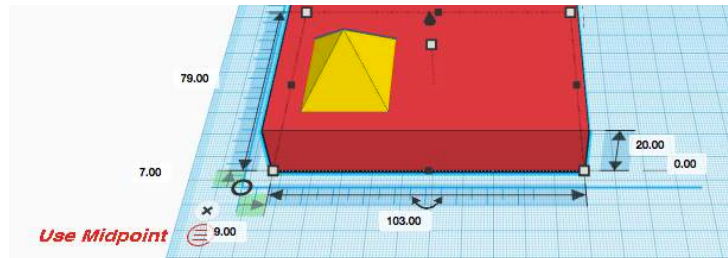

## Your turn. Become a master builder.



## Goal: basic house

Start with a basic house (if you want to be really fancy, add a chimney).

- Step 1: Click and drag a "Box" shape from the Basic Shapes menu to your Workplane.
- Step 2: Change the size of your box to be the size of house that you prefer.
- Step 3: Change the area of your Workplane to the top of the box in order to add your roof.
- Step 4: Add a "Roof" shape on top of your box shape to make a house.
- Step 5: Change the color of your house.

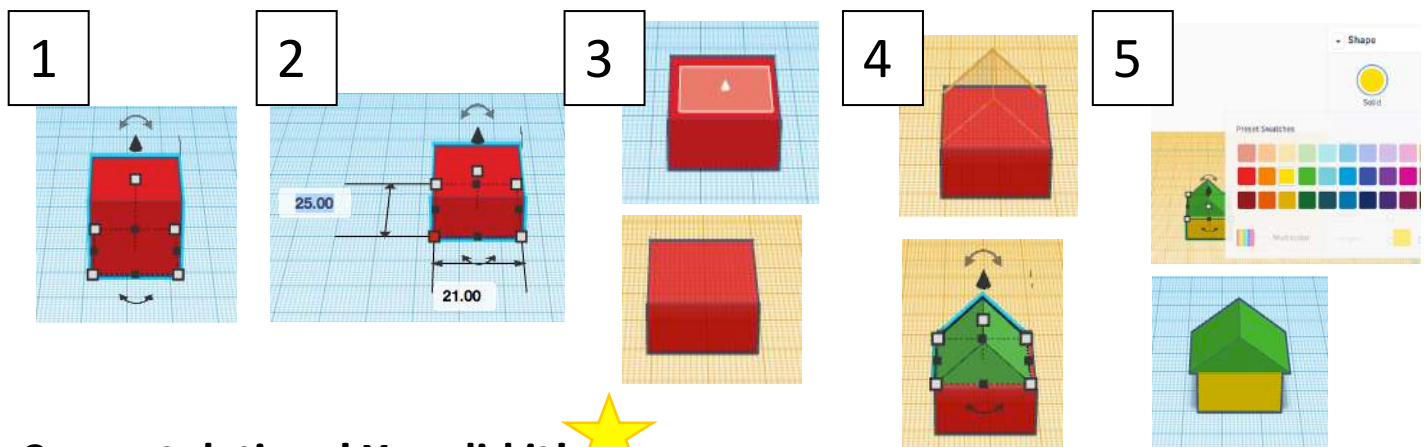
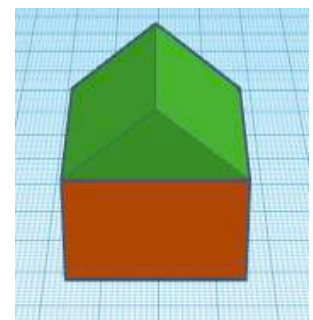

Congratulations! You did it! ★

## Creating your first project: A Keychain

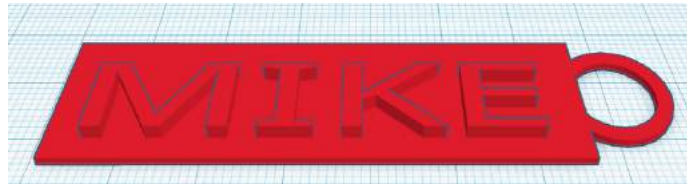

The best way to learn a new skill, is by practicing. And to practice what you've already been shown, we're going to create a personalized keychain.

1. Click on the Create new design button

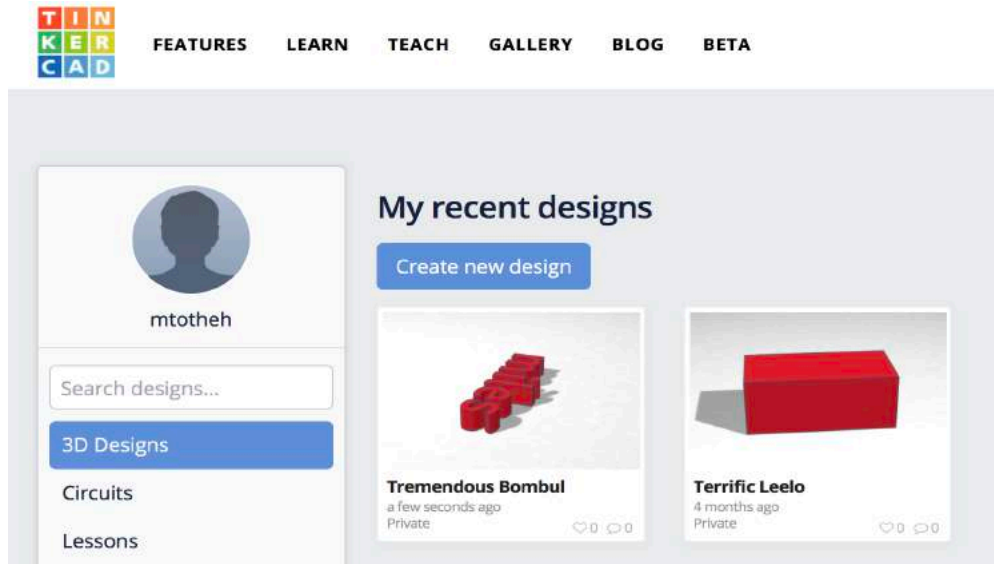

2. Click and drag a box onto the Workplane.

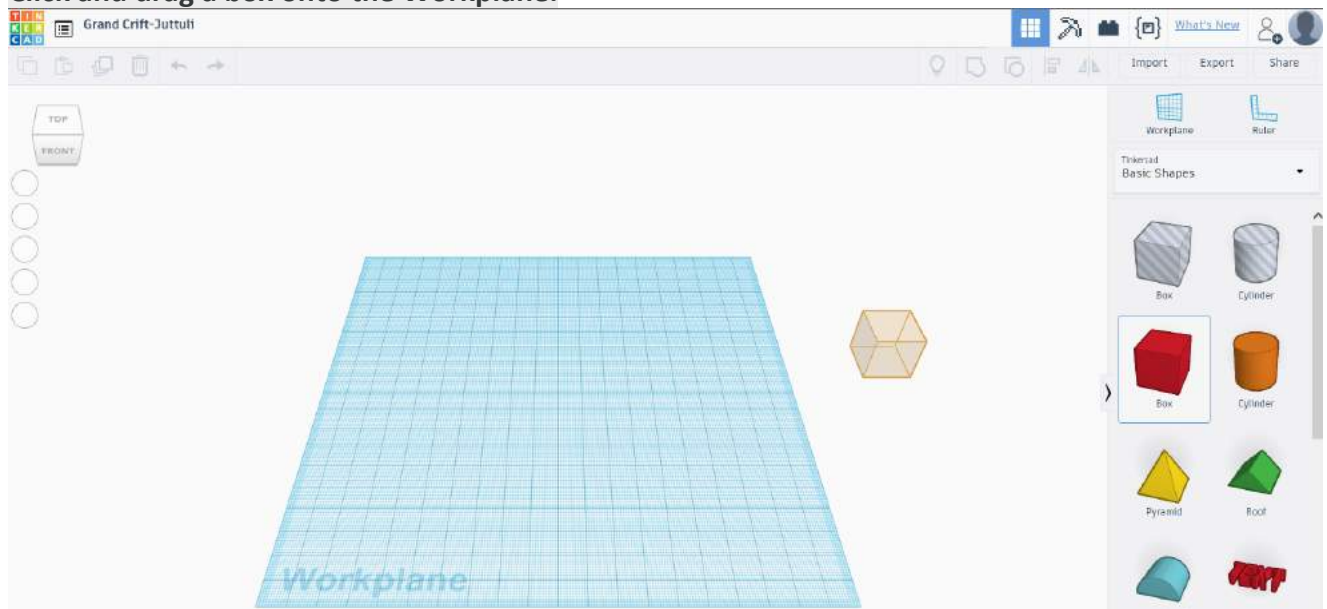

3. Click and drag the box into a rectangle, roughly 77mm long by 22mm deep

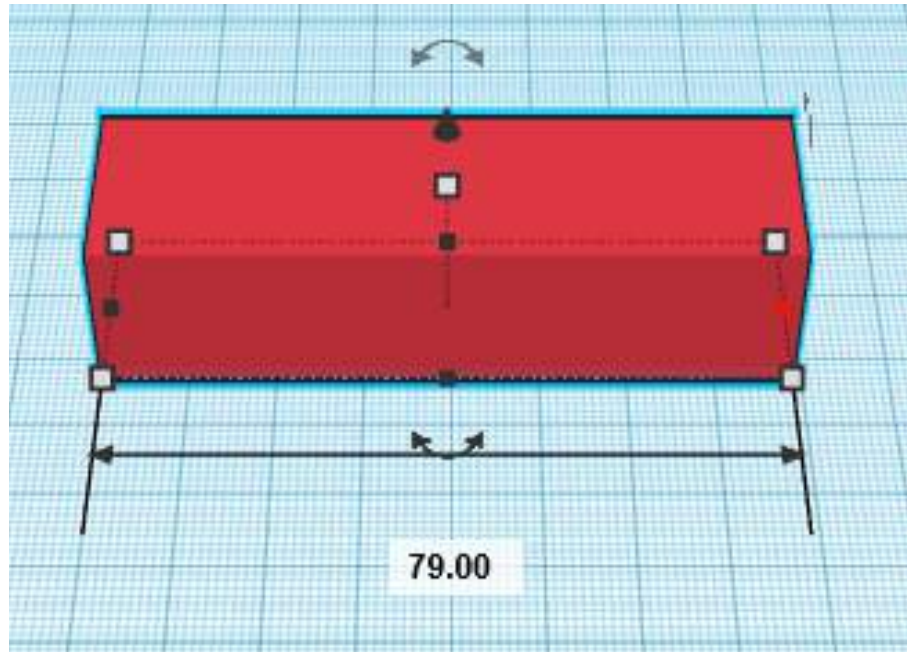

4. Grab the middle handle and reduce the height/thickness to around 3mm.

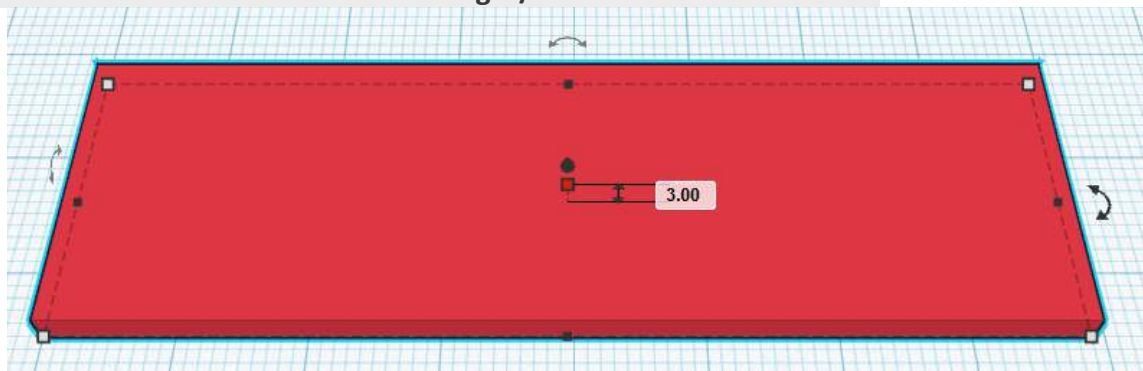

5. Click and drag the Text shape onto the Workplane

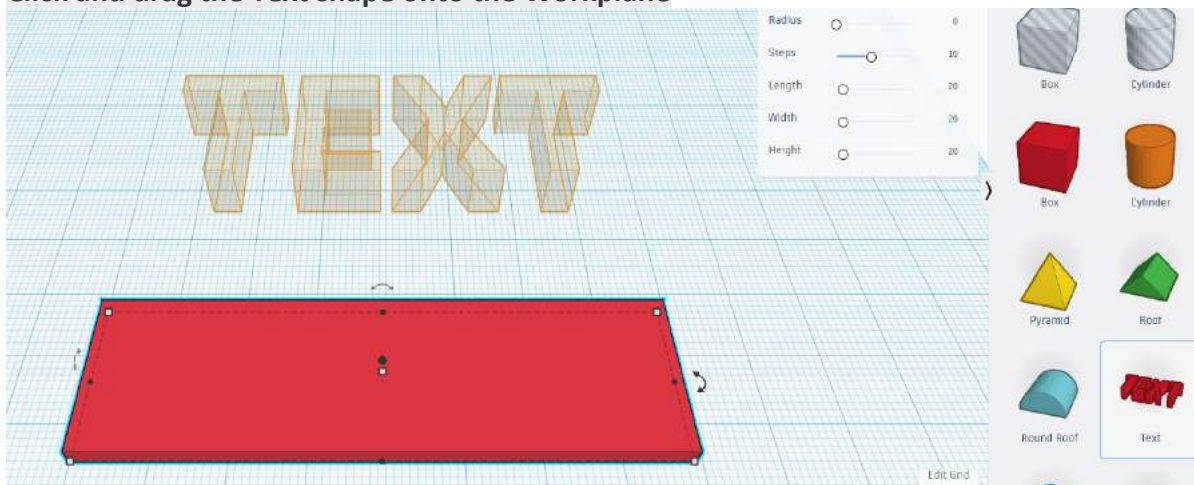

6. Type in your first name in the text box in the Shape menu appears. If your first name is long, you may need to click and drag the side of your box to make it longer.

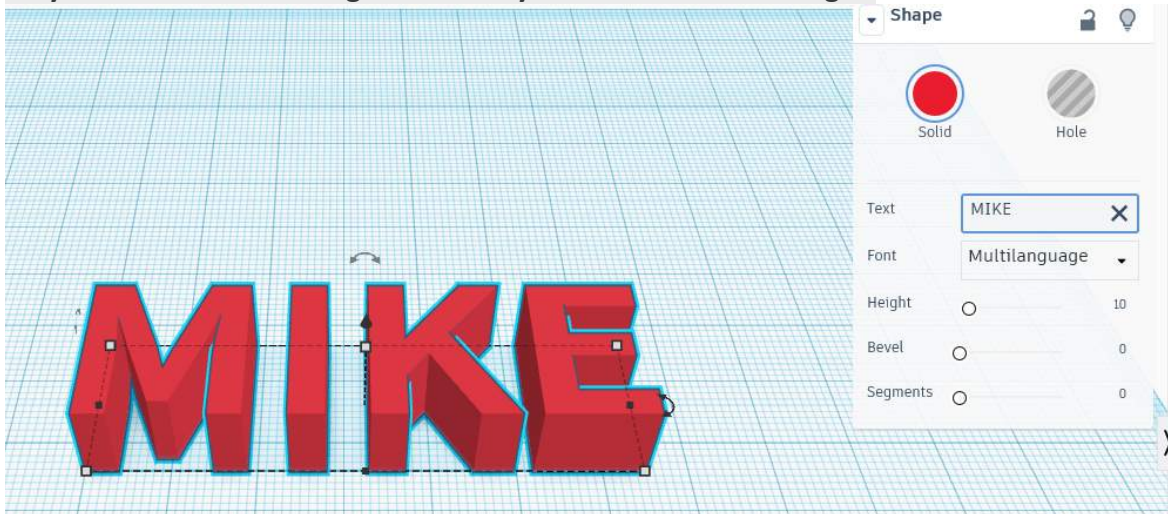

7. Once you've typed your name, drag it on top of your box.

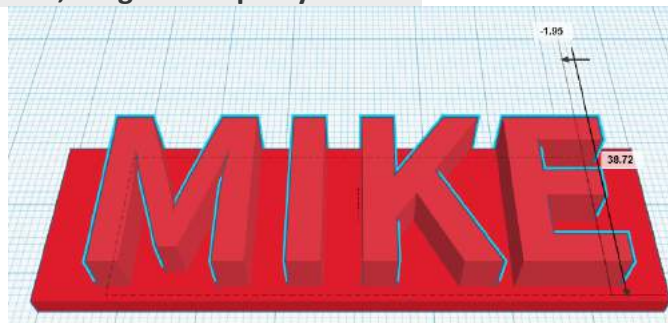

8. Click your middle handle and decrease the thickness of your name to around 6mm.

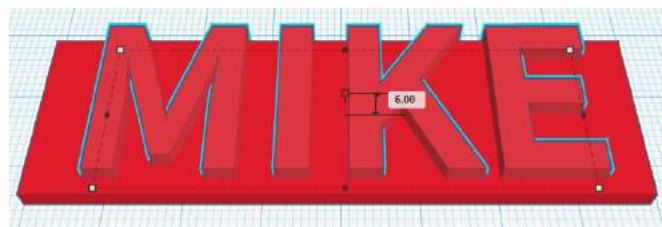

9. Scroll to the bottom of your Basic Shapes menu and drag a tube onto the Workplane.

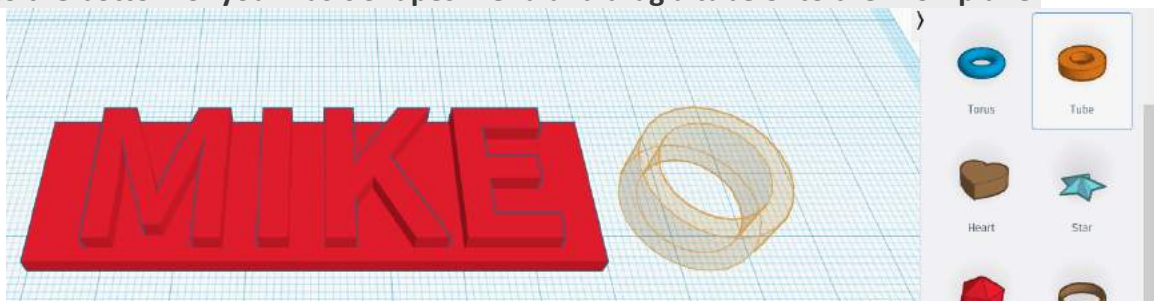

10. Click and drag the middle handle to reduce the thickness of the tube to around 3mm.

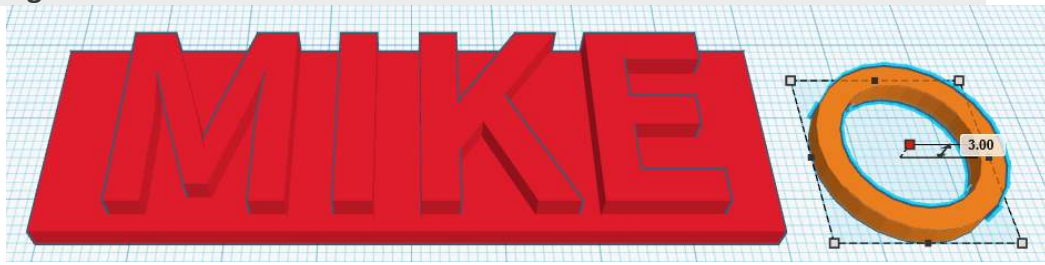

11. Drag your tube and place it so the bottom ¼ (or so) is inside your box.

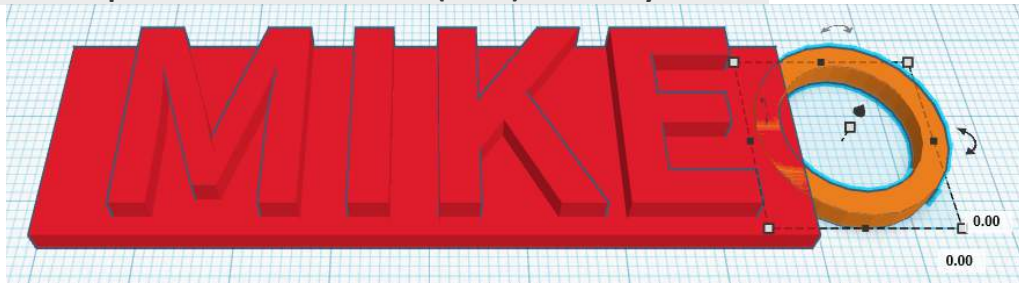

12. In the Shape menu, click on the Solid color dot, and then choose the color red from the color menu.

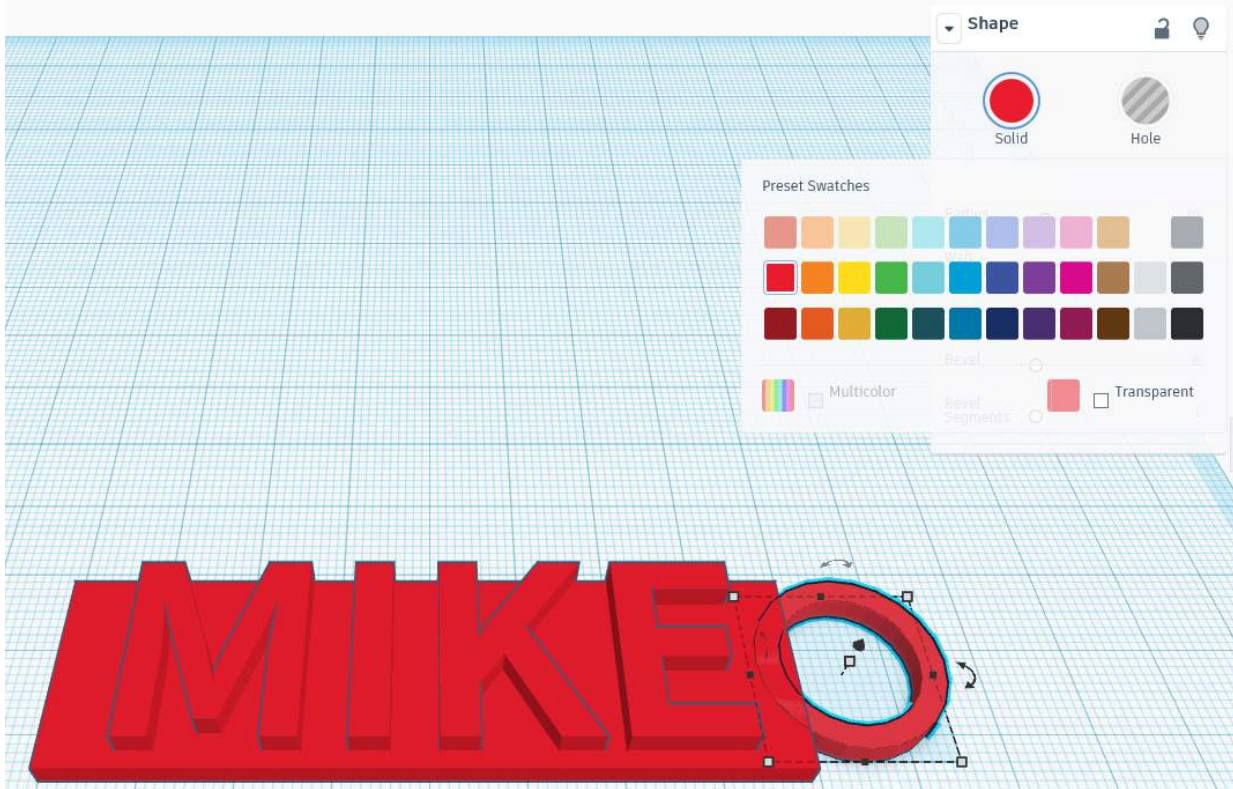

13. Click and drag a square around your entire project.

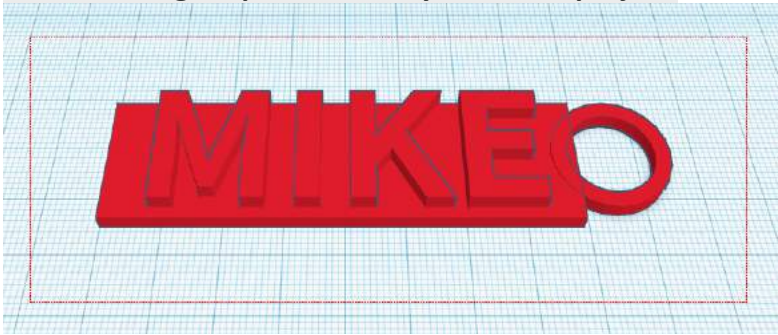

14. Click on the Group button, which will connect all the pieces of your project together.

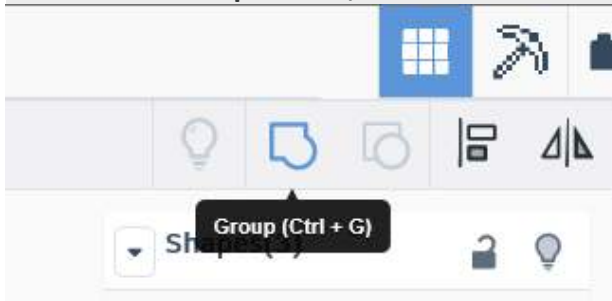

15. Admire your finished keychain!

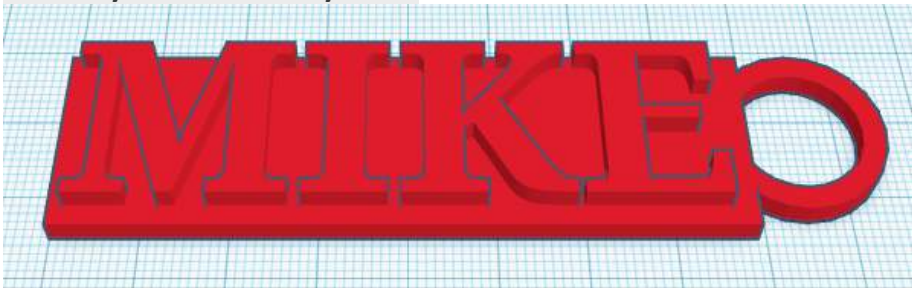

## Changing your project name

You'll notice that Tinkercad automatically assigns any new project you create a name - usually something silly sounding. You can change your project name by clicking on the Tinkercad-assigned project name in the upper left corner of your screen:



Once you click on the name, it becomes a highlighted text box that you can then type over and rename your project whatever you'd like.

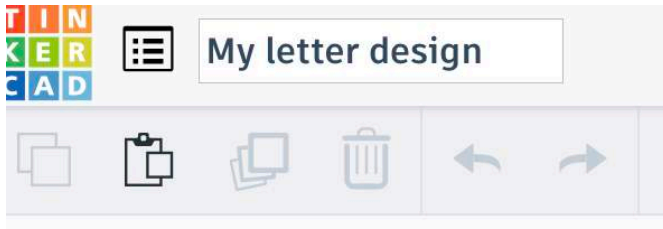

## Saving your project

Saving a project you create in Tinkercad is easy because it's automatically done for you. When you choose to exit your project, you'll see a small green bar appear at the bottom of the screen that says *Saving your work...* Note, until you download your project, it's saved in the cloud (aka, servers at Tinkercad).

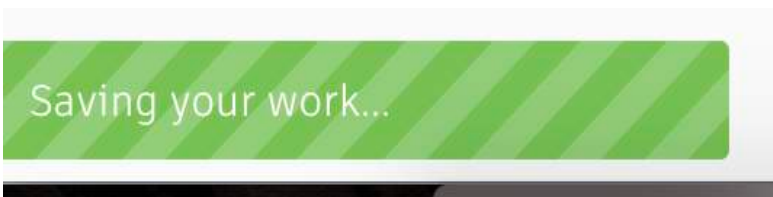

## The Import/Export/Share Menu



## Import

You'll use the Import button to drag and drop a 2D or 3D file, or you can choose one that you've saved from your computer.

- You can download files you want to modify from 3D repository websites (like Thingiverse and MyMiniFactory) onto your computer and upload them into your Tinkercad account here.
- You can also upload pictures saved from online that you want to turn into 3D objects (we'll cover this neat trick later)

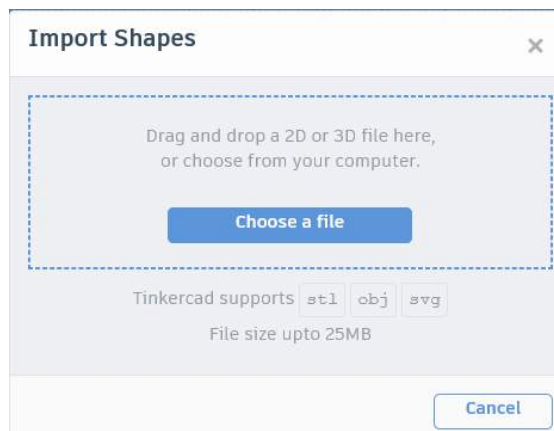

## Export

When you're completely finished with your project, you'll likely want to save it outside of Tinkercad, for later 3D printing. When you're ready for this step, click on the Export button and follow these steps.

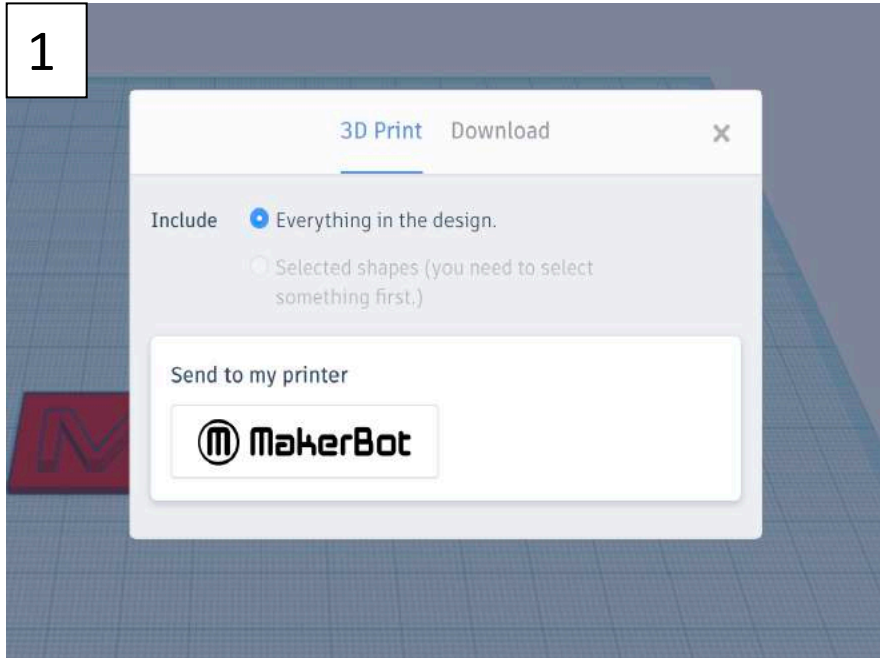

1. Once you click the Export button, a menu appears giving you the option of 3D printing your project IF you have a MakerBot brand 3D printer. If you don't, or if you simply want to save your design, click Download from this same menu.

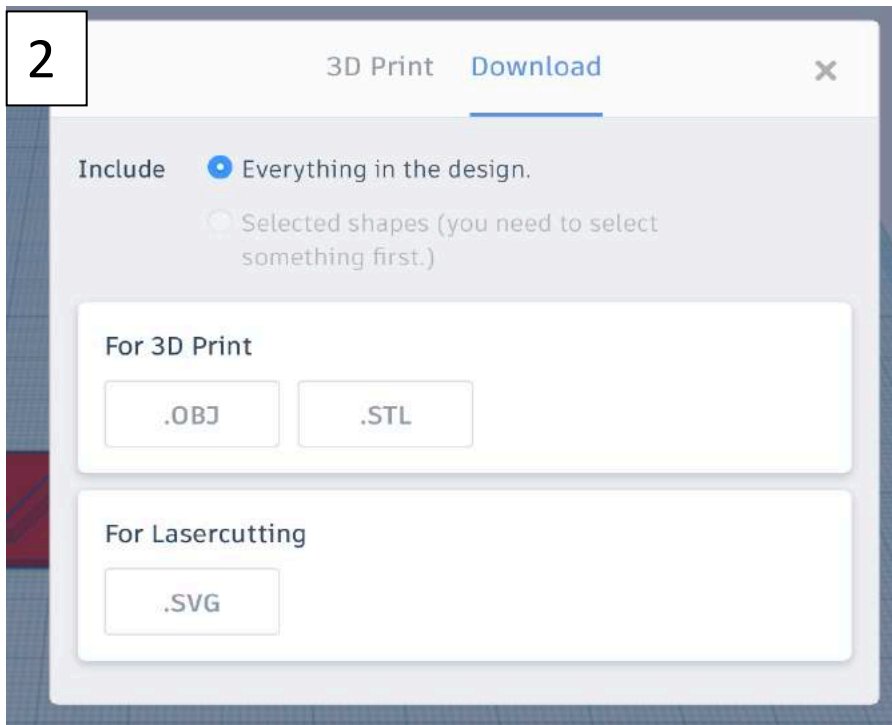

2. Once you click on Download, you'll be given a number of options. Choose to save your object in either the .OBJ or .STL format.

## What Are .STL and .OBJ File Formats for 3D Printing?

### .STL

.STL format is one of the most commonly used file formats for 3D printing. This is due to the fact that most CAD software has the feature of exporting models in .STL format and most 3D printers support it. Specifically, it is a file which "slices" a 3D model into a series of very thin 2D "layers." This output is then used to drive a stereolithography (or similar) machine which produces physical prototypes through layer-by-layer deposition the file generates the surface geometry of the modeled object only.

### .OBJ

.OBJ format is considered to be more complex than .STL file for the fact that it is capable of representing texture, color and other CAD attributes of the three-dimensional object. .OBJ is also easily exported from most CAD tools and is supported by 3D printers.

### Which to choose?

However, according to people's opinion on forums and 3D printing enthusiast platforms, .STL seems to hold a top spot in the list of preference of file formats for 3D printing. The main reason is that this type of file is simpler to use and most mesh repair tools work better with [STL files](#) than .OBJ.

On the other hand, if you are willing to print a multi-color 3D model, you would want to choose .OBJ file format.

### Share

The Share button allows you to share your design with others in a number of ways:

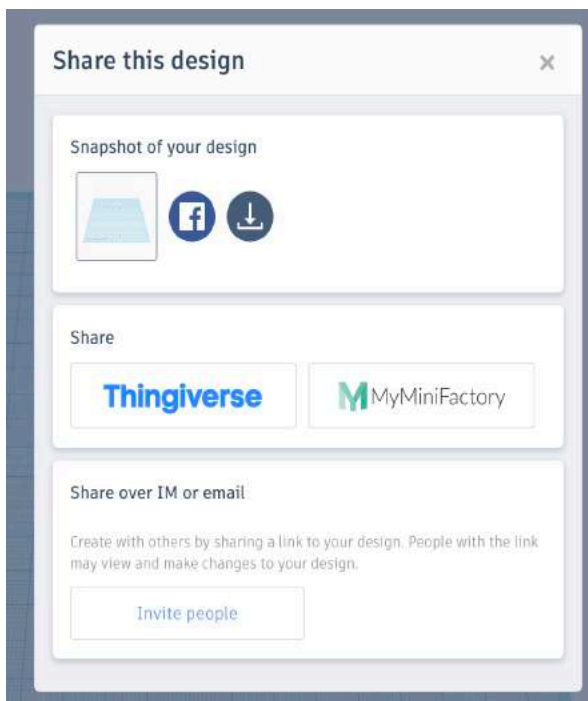

#### 1. Snapshot of your design

You can take a snapshot of your design and post it on Facebook. You can also take a snapshot of your design and download it onto your computer.

#### 2. Share

If you've created an account with either Thingiverse or MyMiniFactory (both are popular 3D model repository websites, where you can upload your own 3D model files or download other creators' files) these buttons will take you to a login window for those sites. Once you log in, you can automatically share your project on either (or both) sites.

#### 3. Share over IM or email

Clicking this button generates a link you can then send to other. People with this link may view and make changes to your design