

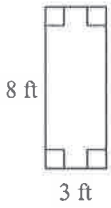
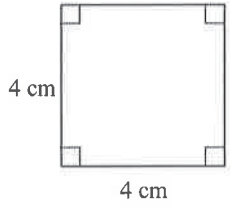

Area of Polygons

Find the area of each.

1)  $A = bh$
 $A = 3 \cdot 8$
 $A = 24 \text{ ft}^2$

2)  $A = s^2$
 $A = 4^2$
 $A = 16 \text{ cm}^2$

3)  $A = bh$
 $A = (2.3)(5)$
 $A = 11.5 \text{ mi}^2$

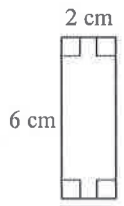
4)  $A = bh$
 $A = 2 \cdot 6$
 $A = 12 \text{ cm}^2$

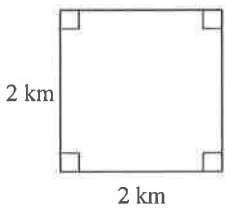
5)  $A = s^2$
 $A = 2^2$
 $A = 4 \text{ km}^2$

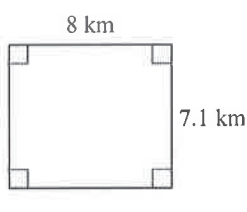
6)  $A = bh$
 $A = 8(7.1)$
 $A = 56.8 \text{ km}^2$

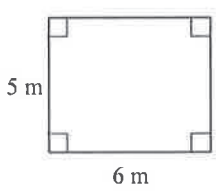
7)  $A = bh$
 $A = (6)(5)$
 $A = 30 \text{ m}^2$

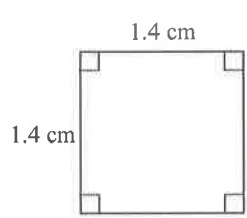
8)  $A = s^2$
 $A = (1.4)^2$
 $A = 1.96 \text{ cm}^2$

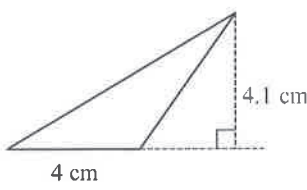
9)  $A = \frac{1}{2}bh$
 $A = \frac{1}{2}(4)(4.1)$
 $A = 8.2 \text{ cm}^2$

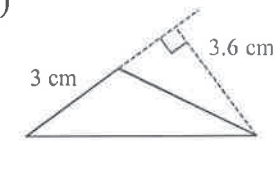
10)  $A = \frac{1}{2}bh$
 $A = \frac{1}{2}(3)(3.6)$
 $A = 5.4 \text{ cm}^2$

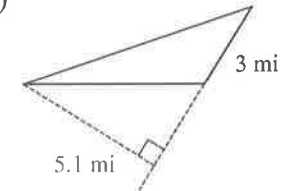
11)  $A = \frac{1}{2}bh$
 $A = \frac{1}{2}(3)(5.1)$
 $A = 12.75 \text{ mi}^2$
 7.65 mi^2

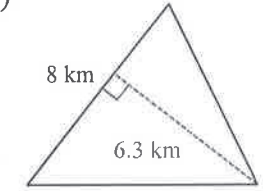
12)  $A = \frac{1}{2}bh$
 $A = \frac{1}{2}(8)(6.3)$
 $A = 25.2 \text{ km}^2$

13)

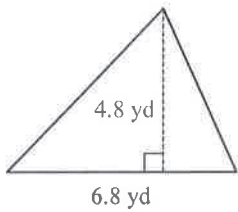

$$A = \frac{1}{2}bh$$

$$A = \frac{1}{2}(6.8)(4.8)$$

$$A = 16.32 \text{ yd}^2$$

14)

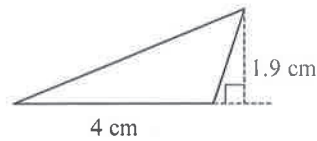

$$A = \frac{1}{2}bh$$

$$A = \frac{1}{2}(4)(1.9)$$

$$A = 3.8 \text{ cm}^2$$

15)

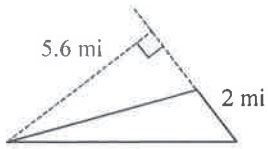

$$A = \frac{1}{2}bh$$

$$A = \frac{1}{2}(7)(5.6)$$

$$A = 19.6 \text{ km}^2$$

16)

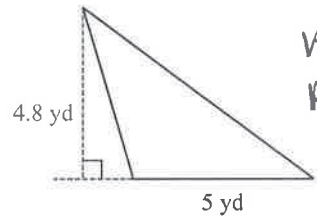

$$A = \frac{1}{2}bh$$

$$A = \frac{1}{2}(5)(4.8)$$

$$A = 12 \text{ yd}^2$$

17)

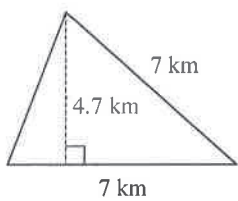

$$A = \frac{1}{2}bh$$

$$A = \frac{1}{2}(7)(4.7)$$

$$A = 16.45 \text{ km}^2$$

18)

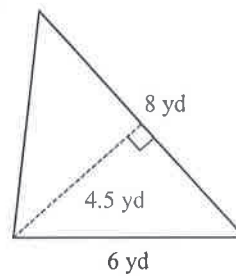

$$A = \frac{1}{2}bh$$

$$A = \frac{1}{2}(6)(8)$$

$$A = 24 \text{ yd}^2$$

19)

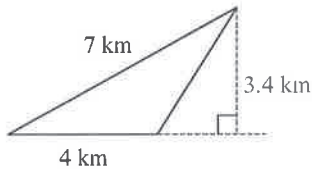

$$A = \frac{1}{2}bh$$

$$A = \frac{1}{2}(4)(3.4)$$

$$A = 6.8 \text{ km}^2$$

20)

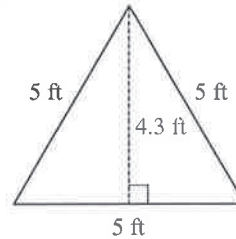

$$A = \frac{1}{2}bh$$

$$A = \frac{1}{2}(5)(4.3)$$

$$A = 10.75 \text{ ft}^2$$

21)

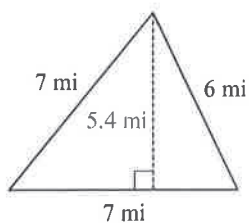

$$A = \frac{1}{2}bh$$

$$A = \frac{1}{2}(7)(5.4)$$

$$A = 18.9 \text{ mi}^2$$

22)

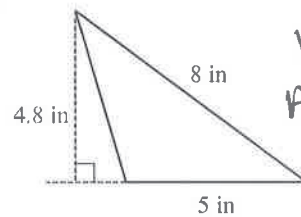

$$A = \frac{1}{2}bh$$

$$A = \frac{1}{2}(5)(4.8)$$

$$A = 12 \text{ in}^2$$

23)

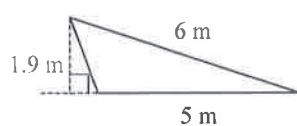

$$A = \frac{1}{2}bh$$

$$A = \frac{1}{2}(5)(1.9)$$

$$A = 4.75 \text{ m}^2$$

24)

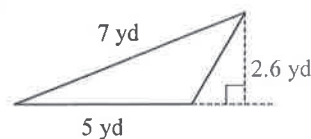

$$A = \frac{1}{2}bh$$

$$A = \frac{1}{2}(5)(2.6)$$

$$A = 6.5 \text{ yd}^2$$

25)

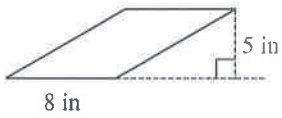

$$A = bh$$

$$A = 8 \cdot 5$$

$$A = 40 \text{ in}^2$$

26)

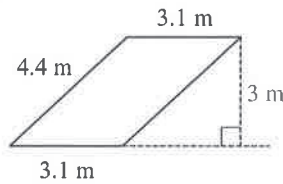

$$A = bh$$

$$A = 3.1(3)$$

$$A = 9.3 \text{ m}^2$$

27)

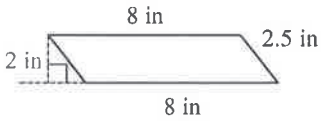

$$A = bh$$

$$A = 8 \cdot 2$$

$$A = 16 \text{ in}^2$$

28)

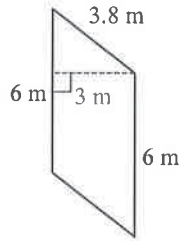

$$A = bh$$

$$A = 6 \cdot 3$$

$$A = 18 \text{ m}^2$$

29)

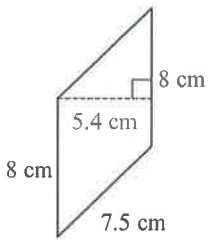

$$A = bh$$

$$A = 8(5.4)$$

$$A = 43.2 \text{ cm}^2$$

30)

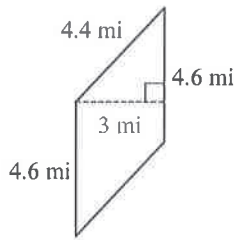

$$A = bh$$

$$A = 4.6(3)$$

$$A = 13.8 \text{ mi}^2$$

31)

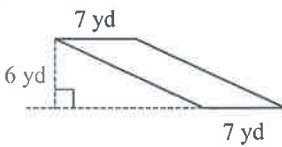

$$A = bh$$

$$A = 7(6)$$

$$A = 42 \text{ yd}^2$$

32)

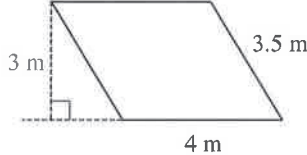

$$A = bh$$

$$A = 4 \cdot 3$$

$$A = 12 \text{ m}^2$$

33)

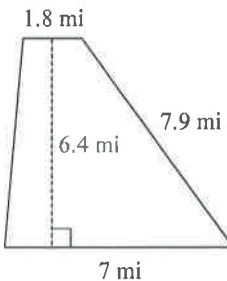

$$A = \frac{1}{2} h (b_1 + b_2)$$

$$A = \frac{1}{2} (6.4)(1.8 + 7)$$

$$A = 28.16 \text{ mi}^2$$

34)

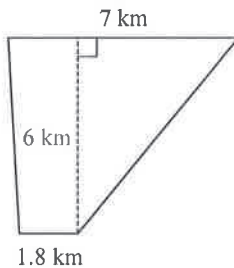

$$A = \frac{1}{2} h (b_1 + b_2)$$

$$A = \frac{1}{2} (6)(7 + 1.8)$$

$$A = 26.4 \text{ km}^2$$

35)

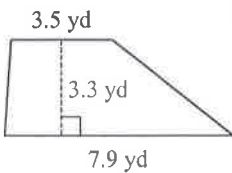

$$A = \frac{1}{2} h (b_1 + b_2)$$

$$A = \frac{1}{2} (3.3)(3.5 + 7.9)$$

$$A = 18.81 \text{ yd}^2$$

36)

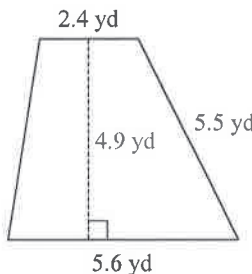

$$A = \frac{1}{2} h (b_1 + b_2)$$

$$A = \frac{1}{2} (4.9)(2.4 + 5.6)$$

$$A = 19.6 \text{ yd}^2$$

37)

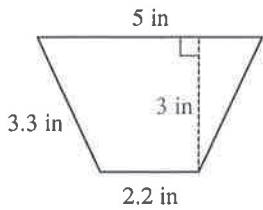

$$A = \frac{1}{2}h(b_1 + b_2)$$

$$A = \frac{1}{2}(3)(5 + 2.2)$$

$$A = 10.8 \text{ in}^2$$

2

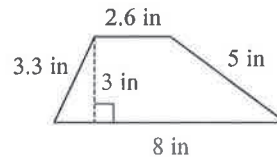

$$A = \frac{1}{2}h(b_1 + b_2)$$

$$A = \frac{1}{2}(3)(2.6 + 8)$$

$$A = 15.9 \text{ in}^2$$

39)

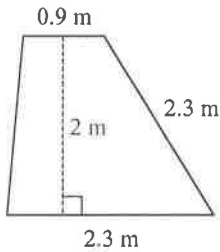

$$A = \frac{1}{2}h(b_1 + b_2)$$

$$A = \frac{1}{2}(2)(0.9 + 2.3)$$

$$A = 3.2 \text{ m}^2$$

40)

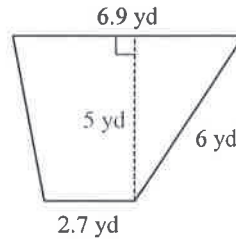

$$A = \frac{1}{2}h(b_1 + b_2)$$

$$A = \frac{1}{2}(5)(6.9 + 2.7)$$

$$A = 24 \text{ yd}^2$$

Find the area of each circle. Give your answer in terms of π .

41)

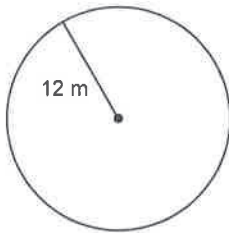

$$A = \pi R^2$$

$$A = \pi (12)^2$$

$$A = 144\pi \text{ m}^2$$

42)

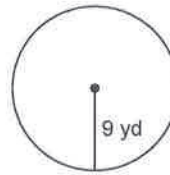

$$A = \pi R^2$$

$$A = \pi (9)^2$$

$$A = 81\pi \text{ yd}^2$$

43)



$$A = \pi R^2$$

$$A = \pi (10)^2$$

$$A = 100\pi \text{ yd}^2$$

44)

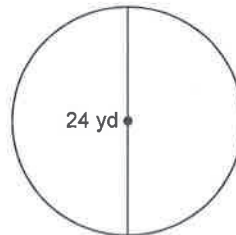

$$A = \pi R^2$$

$$A = \pi (12)^2$$

$$A = 144\pi \text{ yd}^2$$

Find the area of each. Use your calculator's value of π . Round your answer to the nearest tenth.

45)

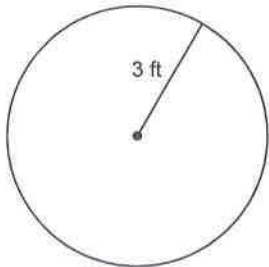

$$A = \pi R^2$$

$$A = \pi (3)^2$$

$$A = 9\pi$$

$$A \approx 28.3 \text{ ft}^2$$

46)

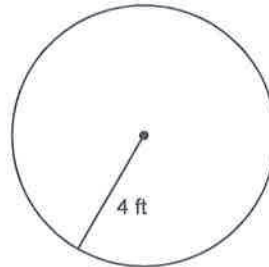

$$A = \pi R^2$$

$$A = \pi (4)^2$$

$$A = 16\pi$$

$$A \approx 50.3 \text{ ft}^2$$

47)

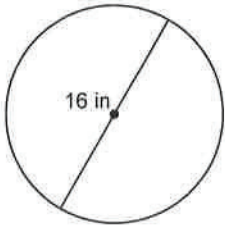

$$A = \pi R^2$$

$$A = \pi (8)^2$$

$$A = 64\pi$$

$$A \approx 201.1 \text{ in}^2$$

48)

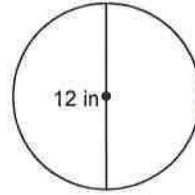

$$A = \pi R^2$$

$$A = \pi (6)^2$$

$$A = 36\pi$$

$$A \approx 113.1 \text{ in}^2$$

Find the area of each regular polygon. Round your answer to the nearest tenth if necessary. $A = \frac{1}{2} Pa$

49)

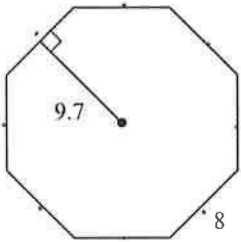

$$P = 8(8)$$

$$P = 64$$

$$a = 9.7$$

$$A = \frac{1}{2} Pa$$

$$A = \frac{1}{2}(64)(9.7)$$

$$A = 310.4 \text{ units}^2$$

50)

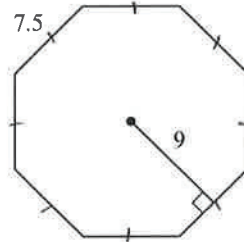

$$P = 8(7.5)$$

$$P = 60$$

$$a = 9$$

$$A = \frac{1}{2} Pa$$

$$A = \frac{1}{2}(60)(9)$$

$$A = 270 \text{ units}^2$$

51)

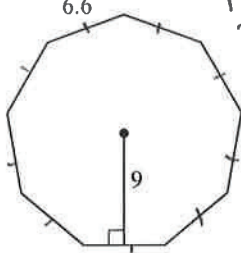

$$P = 8(6.6)$$

$$P = 59.4$$

$$a = 9$$

$$A = \frac{1}{2} Pa$$

$$A = \frac{1}{2}(59.4)(9)$$

$$A = 267.3 \text{ units}^2$$

52)

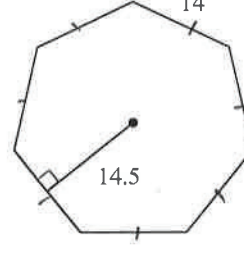

$$P = 8(14)$$

$$P = 98$$

$$a = 14.5$$

$$A = \frac{1}{2} Pa$$

$$A = \frac{1}{2}(98)(14.5)$$

$$A = 710.5 \text{ units}^2$$

53)

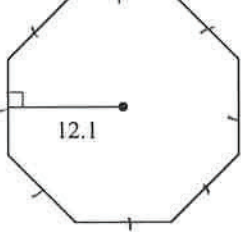

$$P = 8(10)$$

$$P = 80$$

$$a = 12.1$$

$$A = \frac{1}{2} Pa$$

$$A = \frac{1}{2}(80)(12.1)$$

$$A = 484 \text{ units}^2$$

54)

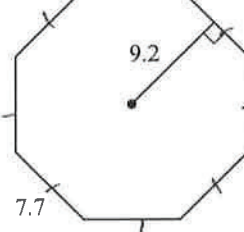

$$P = 8(7.7)$$

$$P = 61.6$$

$$a = 9.2$$

$$A = \frac{1}{2} Pa$$

$$A = \frac{1}{2}(61.6)(9.2)$$

$$A = 283.36 \text{ units}^2$$

55)

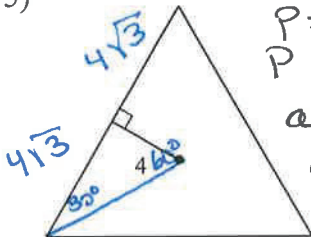

$$P = 3(4\sqrt{3})$$

$$P = 12\sqrt{3}$$

$$a = 4$$

$$A = \frac{1}{2} Pa$$

$$A = \frac{1}{2}(12\sqrt{3})(4)$$

$$A = 24\sqrt{3} \text{ units}^2$$

$$A \approx 83.1 \text{ units}^2$$

56)

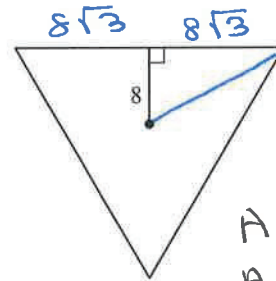

$$P = 3(8\sqrt{3})$$

$$P = 24\sqrt{3}$$

$$a = 8$$

$$A = \frac{1}{2} Pa$$

$$A = \frac{1}{2}(24\sqrt{3})(8)$$

$$A = 96\sqrt{3}$$

$$A \approx 332.6 \text{ units}^2$$

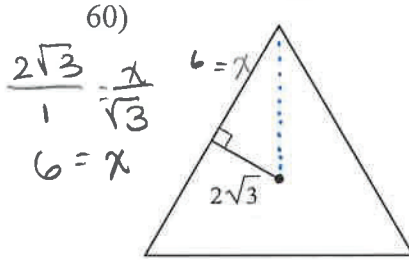
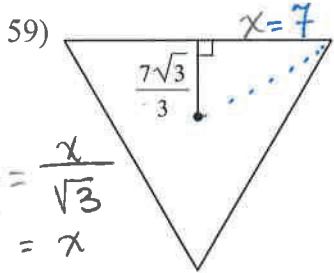
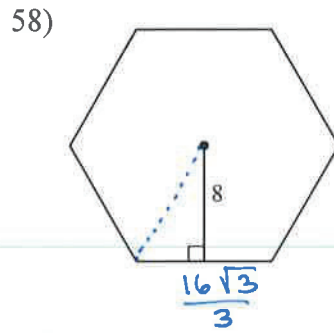
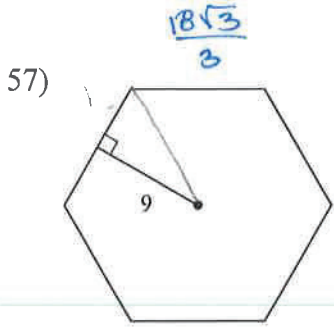

$$\frac{7\sqrt{3}}{3} = \frac{x}{\sqrt{3}}$$

$$7 = x$$

$$\frac{2\sqrt{3}}{1} = \frac{x}{\sqrt{3}}$$

$$6 = x$$

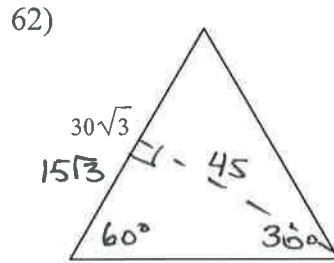
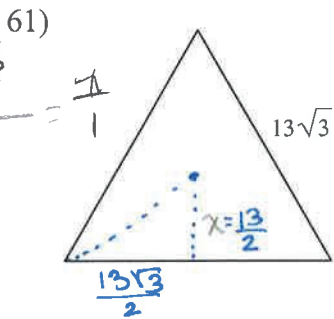

$$A = \frac{1}{2}bh$$

$$= \frac{1}{2}(30\sqrt{3})(45)$$

$$= 675\sqrt{3}$$

$$A \approx 1169.1 \text{ units}^2$$

$$\frac{13\sqrt{3}}{2} = \frac{h}{1}$$

$$\frac{13}{2}$$

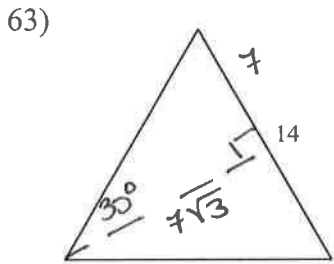

$$A = \frac{1}{2}bh$$

$$= \frac{1}{2}(14)(7\sqrt{3})$$

$$= 49\sqrt{3}$$

$$A \approx 84.9 \text{ units}^2$$

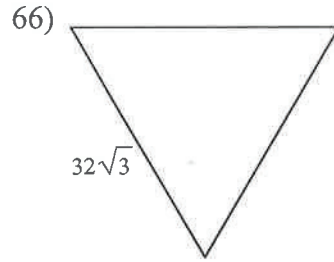
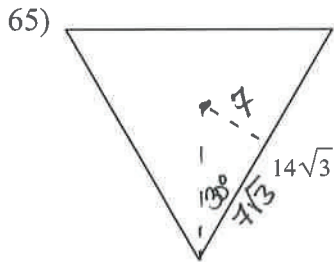
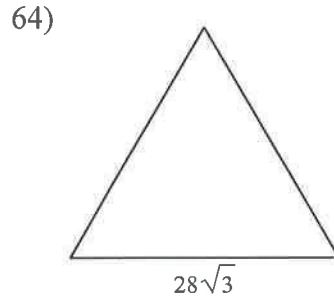

$$P = 3(14\sqrt{3})$$

$$= 42\sqrt{3}$$

$$a = 7$$

$$A = \frac{1}{2}Pa$$

$$= \frac{1}{2}(42\sqrt{3})(7)$$

$$= 147\sqrt{3}$$

$$A \approx 254.6 \text{ units}^2$$

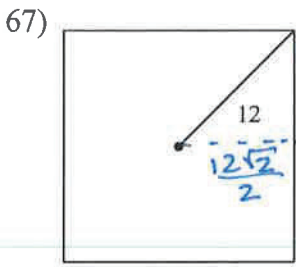

$$\Delta = 12\sqrt{2}$$

$$A = \Delta^2$$

$$= (12\sqrt{2})^2$$

$$= 144 \cdot 2$$

$$A = 288 \text{ units}^2$$

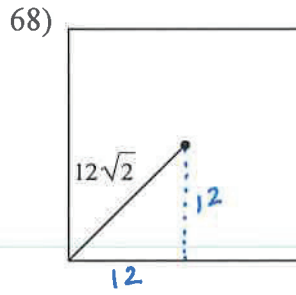

$$\Delta = 24$$

$$A = \Delta^2$$

$$A = (24)^2$$

$$A = \cancel{576} \text{ units}^2$$

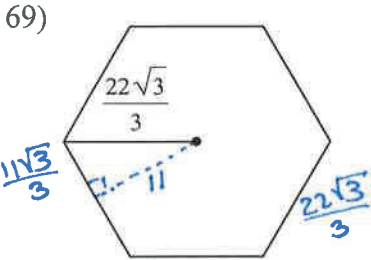

$$\Delta = 12$$

$$A = \Delta^2$$

$$A = (12)^2$$

$$A = \cancel{36} \text{ units}^2$$

$$144$$

$$P = 12(4)$$

$$P = 48$$

$$a = 6$$

$$A = \frac{1}{2}Pa$$

$$= \frac{1}{2}(48)(6)$$

$$A = 144 \text{ units}^2$$

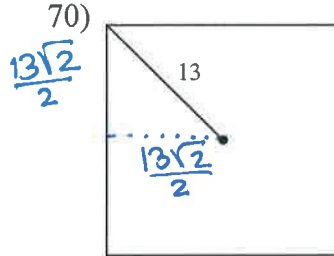

$$\Delta = \left(\frac{13\sqrt{2}}{2}\right)^2$$

$$\Delta = 13\sqrt{2}$$

$$A = \Delta^2$$

$$= (13\sqrt{2})^2$$

$$= 169 \cdot 2 \quad A = \cancel{53} \quad A = 338 \text{ u}^2$$

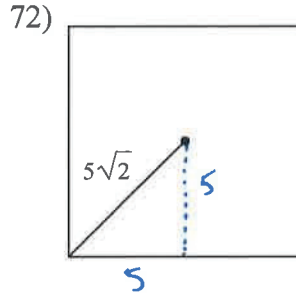
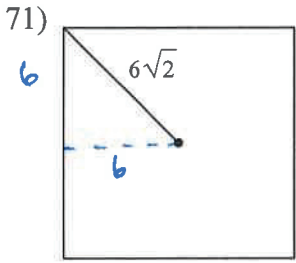

$$A = 100 \text{ units}^2$$

Find the area of each trapezoid.

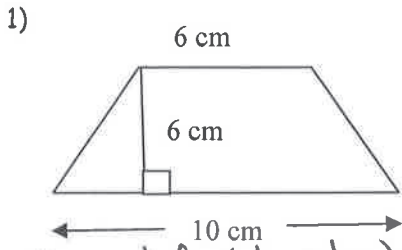

$$A = \frac{1}{2} h (b_1 + b_2)$$

$$A = \frac{1}{2} (6)(10 + 6)$$

$$A = 48 \text{ cm}^2$$

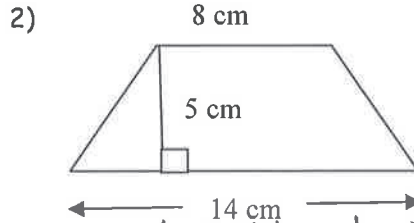

$$A = \frac{1}{2} h (b_1 + b_2)$$

$$A = \frac{1}{2} (5)(8 + 14)$$

$$A = 55 \text{ cm}^2$$

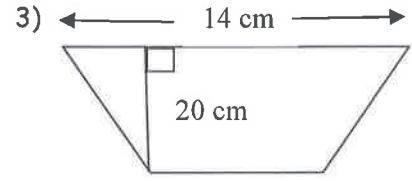

$$A = \frac{1}{2} h (b_1 + b_2)$$

$$A = \frac{1}{2} (20)(14 + 9)$$

$$A = 230 \text{ cm}^2$$

Find the area of each rhombus. Round to the nearest tenth, if necessary.

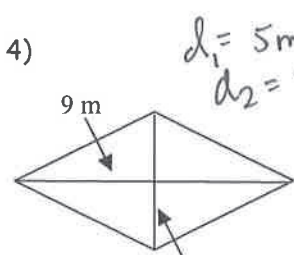

$$A = \frac{1}{2} d_1 d_2$$

$$A = \frac{1}{2} (5 \times 9)$$

$$A = 22.5 \text{ m}^2$$

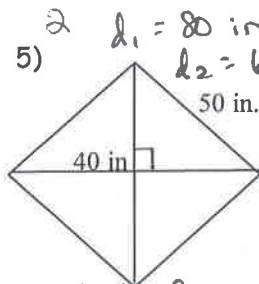

$$A = \frac{1}{2} d_1 d_2$$

$$A = \frac{1}{2} (80 \times 60)$$

$$A = 240 \text{ in}^2$$

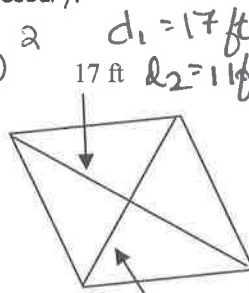

$$A = \frac{1}{2} d_1 d_2$$

$$A = \frac{1}{2} (17 \times 11)$$

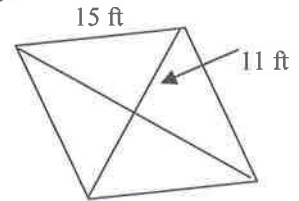

$$A = 93.5 \text{ ft}^2$$

Find the area of each kite. Round your answer to the nearest tenth.

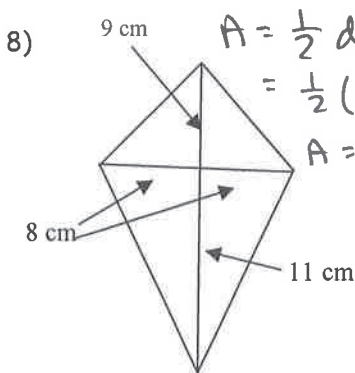

$$A = \frac{1}{2} d_1 d_2$$

$$= \frac{1}{2} (16 \times 20)$$

$$A = 160 \text{ cm}^2$$

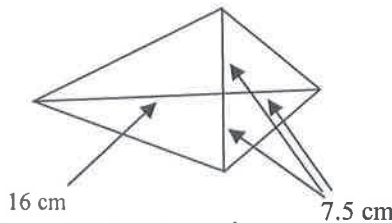

$$A = \frac{1}{2} d_1 d_2$$

$$A = \frac{1}{2} (16 + 7.5)(7.5 + 7.5)$$

$$A = 176.25 \text{ cm}^2$$

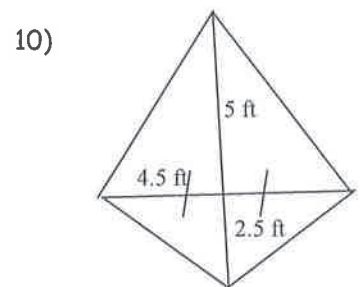

$$A = \frac{1}{2} d_1 d_2$$

$$A = \frac{1}{2} (4.5 + 4.5)(5 + 2.5)$$

$$A = 33.75 \text{ ft}^2$$

Find the area of each of the following.

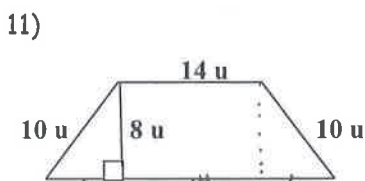

$$A = \frac{1}{2} h (b_1 + b_2)$$

$$A = \frac{1}{2} (8)(14 + 12 + 14)$$

$$A = 160 \text{ u}^2$$

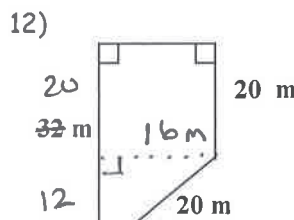

$$A = \frac{1}{2} h (b_1 + b_2)$$

$$A = \frac{1}{2} (12)(16 + 32)$$

$$A = 416 \text{ m}^2$$

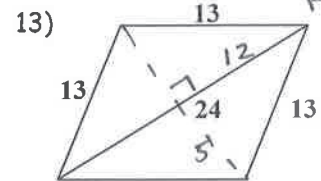

Rhombus!

$$A = \frac{1}{2} d_1 d_2$$

$$A = \frac{1}{2} (10)(24)$$

$$A = 120 \text{ units}^2$$

14) Rhombus ABCD with AC = 10 and BD = 17

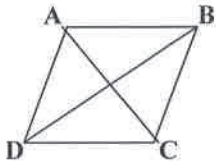

$$A = \frac{1}{2} d_1 d_2$$

$$A = \frac{1}{2} (10)(17)$$

$$A = 85$$

15)

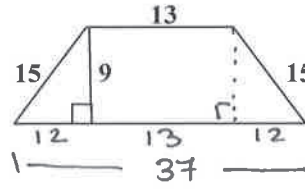

$$A = \frac{1}{2} h (b_1 + b_2)$$

$$A = \frac{1}{2} (9)(13 + 37)$$

$$A = 225$$

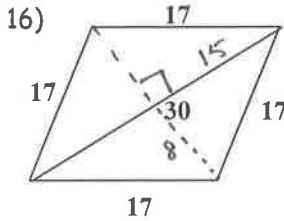

$$A = \frac{1}{2} d_1 d_2$$

$$A = \frac{1}{2} (16)(30)$$

$$A = 240$$

17)

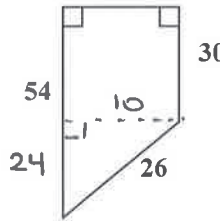

$$A = \frac{1}{2} h (b_1 + b_2)$$

$$A = \frac{1}{2} (10)(30 + 54)$$

$$A = 420$$

Find the area of the following.

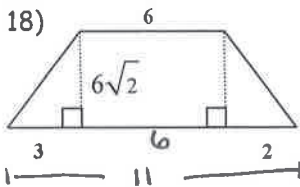

$$A = \frac{1}{2} h (b_1 + b_2)$$

$$A = \frac{1}{2} (6\sqrt{2})(11 + 6)$$

$$A = 3\sqrt{2}(17)$$

$$A = 51\sqrt{2}$$

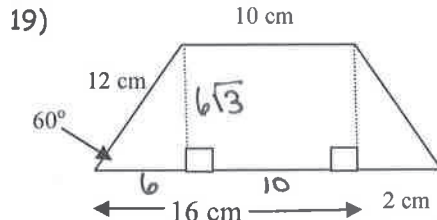

$$A = \frac{1}{2} h (b_1 + b_2)$$

$$A = \frac{1}{2} (6\sqrt{3})(10 + 18)$$

$$A = 3\sqrt{3}(28)$$

$$A = 84\sqrt{3} \text{ cm}^2$$

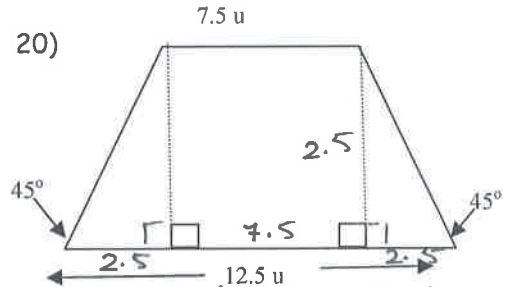

$$A = \frac{1}{2} h (b_1 + b_2)$$

$$A = \frac{1}{2} (2.5)(7.5 + 12.5)$$

$$A = 25 u^2$$

21) The median is equal to 25 cm and the height is 8 cm.

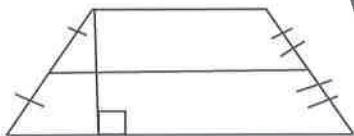

$$A = h \cdot m$$

$$A = 8 \cdot 25$$

$$A = 200 \text{ cm}^2$$

22) The median is equal to 24 m and the height is 9 m.

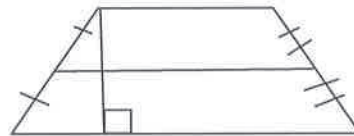

$$A = h \cdot m$$

$$A = 9 \cdot 24$$

$$A = 216 \text{ m}^2$$

23) The area of a rhombus is 90 square units. If one diagonal is 10 units, find the length of the other diagonal.

$$A = \frac{1}{2} d_1 d_2$$

$$90 = \frac{1}{2} (10) d_2$$

$$90 = 5 d_2$$

$$18 = d_2$$

The other diagonal is 18 units.

24) The area of a trapezoid is 75 square inches, and its two bases are 8 and 17 inches long. Find the height of the trapezoid.

$$A = \frac{1}{2} h (b_1 + b_2)$$

$$75 = \frac{1}{2} h (8 + 17)$$

$$150 = 25 h$$

$$6 = h$$

The height is 6 inches.

25) A rhombus has a perimeter of 100 meters and a diagonal 30 meters long. Find the area of the rhombus.

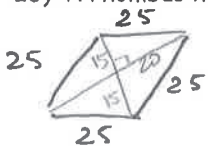

$$A = \frac{1}{2} d_1 d_2$$

$$A = \frac{1}{2} (30)(40)$$

$$A = 600 \text{ m}^2$$

- 26) The area of a trapezoid is 126 square feet with a height of 9 feet and the length of one of the bases is 13 ft. Find the length of the second base.
- $$A = \frac{1}{2}h(b_1 + b_2)$$
- $$126 = \frac{1}{2}(9)(b_1 + 13)$$
- $$252 = 9b_1 + 117$$
- $$135 = 9 \cdot b_1$$
- $$15 = b_1$$
- The second base is 15 ft long.

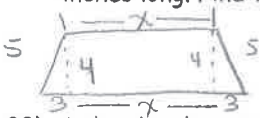
- 27) The area of an isosceles trapezoid is 77 square inches, the height measures 4 inches and the legs are 5 inches long. Find the lengths of the bases.
- 
- $$A = \frac{1}{2}h(b_1 + b_2)$$
- $$77 = \frac{1}{2}(4)(x + b + x)$$
- $$38.5 = 2x + b$$
- $$32.5 = 2x$$
- $$16.25 = x$$
- The legs are 16.25 in and 22.25 in long.

- 28) A rhombus has an area of 20 and one diagonal of length 12. Find the length of the other diagonal.
- $$A = \frac{1}{2}d_1 d_2$$
- $$20 = \frac{1}{2}(12)d_2$$
- $$20 = 6d_2$$
- $$d_2 \approx 3.3$$
- The other diagonal is approximately 3.3 units long.

- 29) A trapezoid has a height of 10, one base of length 5, and an area of 60. Find the length of the other base.
- $$A = \frac{1}{2}h(b_1 + b_2)$$
- $$60 = \frac{1}{2}(10)(5 + b_2)$$
- $$12 = 5 + b_2$$
- $$b_2 = 7$$
- The other base is 7 units long.

- 30) The length of one of the diagonals of a kite is 4 cm longer than twice the length of the other diagonal. The area of the kite is 15 cm². Find the length of each diagonal.
- $$A = \frac{1}{2}d_1 d_2$$
- $$15 = \frac{1}{2}(x)(2x + 4)$$
- $$30 = 2x^2 + 4x$$
- $$15 = x^2 + 2x$$
- $$0 = x^2 + 2x - 15$$
- $$(x+5)(x-3) = 0$$
- $$x = 3$$
- $$2x + 4 = 10$$
- The diagonals are 3 cm and 10 cm.

- 31) The length of one of the diagonals of a rhombus is 5 cm less than the length of the other diagonal. The area of the rhombus is 33 cm². Find the length of each diagonal.
- $$d_1 = x$$
- $$d_2 = x - 5$$
- $$A = \frac{1}{2}d_1 d_2$$
- $$33 = \frac{1}{2}(x)(x - 5)$$
- $$66 = x^2 - 5x$$
- $$0 = x^2 - 5x - 66$$
- $$(x - 11)(x + 6)$$
- $$x = 11$$
- $$x - 5 = 6$$
- The diagonals measure 11 cm and 6 cm.

- 32) The lengths of the bases of an isosceles trapezoid are shown below.

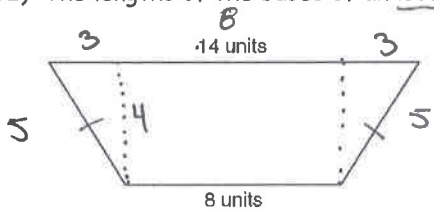

- If the perimeter of this trapezoid is 32 units, what is its area?
- A 44 square units
 B 110 square units
 C 88 square units
 D 55 square units
- $$A = \frac{1}{2}h(b_1 + b_2)$$
- $$A = \frac{1}{2}(4)(8 + 14)$$
- $$A = 44$$