



ثانوية التكنولوجيا التطبيقية
Applied Technology High School

Mechanical Workshop

Module 2: Measurements

PREPARED BY

Academic Services

January 2013

Module 2: Measurements

Module Objectives

After the completion of this module, the student will be able to:

1. Take linear measurements to an accuracy of ± 0.5 mm using a centimeter steel rule.
2. Read inside, outside and depth/thickness measurements to an accuracy of ± 0.02 mm, and ± 0.05 mm using Vernier calipers.
3. Read outside diameter measurements to an accuracy of ± 0.01 mm using micrometer.
4. Maintaining and storing steel rules, calipers and micrometers.

Module Contents

	Topic	Page No.
1	Introduction to Measurements	3
2	Steel rule	3
3	Practical Task 1	5
4	Vernier caliper	6
5	Practical Task 2	10
6	Micrometers	11
7	Practical Task 3	13
8	Review Questions	15

1. Introduction to Measurements

The science that deals with all theoretical and practical aspects of measurement is called **metrology**.

System of measurement

The main two systems of measurements are:

1. The METRIC system:

The basic unit of length in the metric system is the meter.

2. The IMPERIAL system:

The basic unit of length in the Imperial system is the yard.

The METRIC system nowadays is used in most countries.

2. Steel Rules

Most metric rules are divided into millimeter or half millimeter graduations.

They are numbered every 10 mm as shown in Fig. 2.1.

The measurement is determined by counting the number of millimeters.

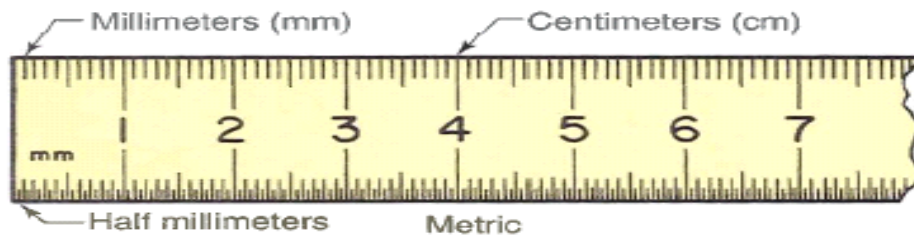

Fig. 2.1: metric rules

2.1 Using the steel rule

Always look straight down at 90° to the rule. Using the datum edge to help you measure correctly. If you look from the side, you can get inaccurate measurements. See Fig. 2.2.

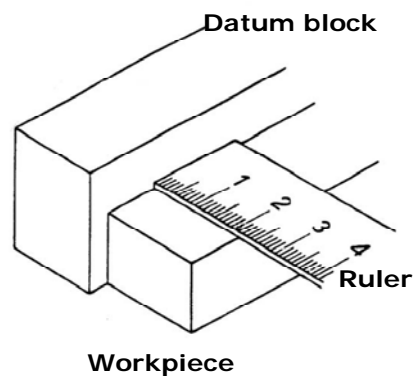

Fig. 2.2: Using the steel ruler

2.2 Other uses of steel rule

The edge of the rule is ground flat. You can use the edge of the rule to check whether the work-piece edges are flat or not as illustrated in Fig. 2.3.a & Fig. 2.3b.

Figure 2.3.a illustrates that there are no gaps between the work piece and the rule; this means that the work piece edges are flat. While Figure 2.3.b shows that there are some gaps between the work piece and the rule; this means that the work piece edges are not flat.

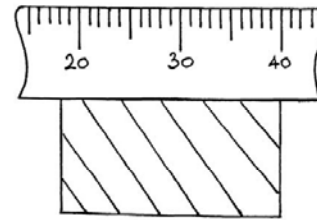

Fig. 2.3.a

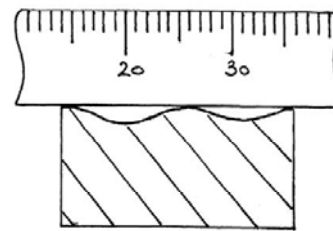

Fig. 2.3.b

2.3 Maintaining the steel rule

The steel rule is an accurate instrument that should be treated with extra care. The following points should be taken in consideration when using the steel rule.

1. Keep the rule clean and lightly oiled.
2. Protect it from damage.
3. Never use it as a screwdriver.
4. Never use the end as a scraper.
5. Never bend or twist a steel ruler.

3. Practical Task 1

You will be given a V-Block similar to the one shown in Fig.2.4. Use the steel rule to measure the dimensions shown in Fig. 2.5. Record your measurements in the table below.



Fig.2.4: V-Block

Note: The accuracy of your readings should be in a range of 0.5 mm

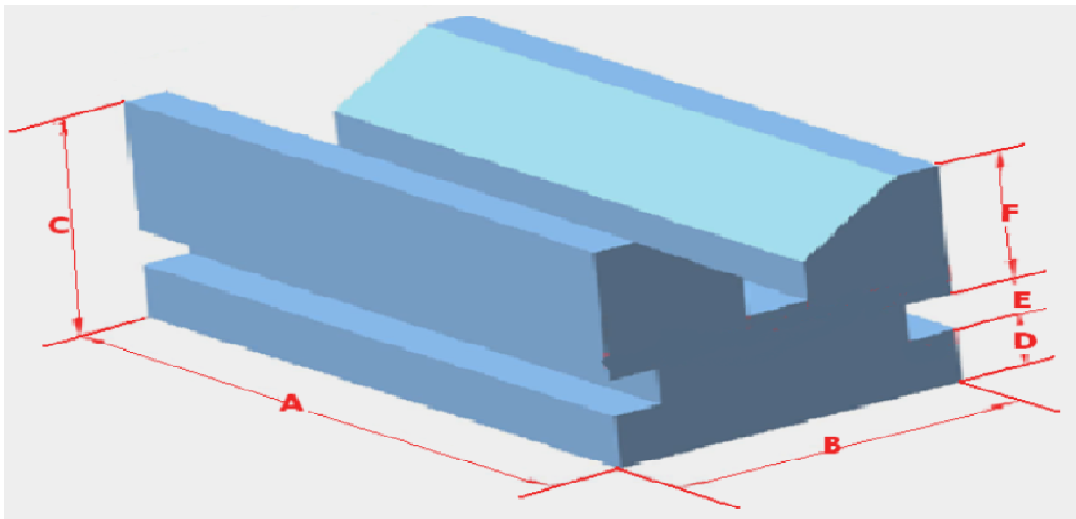

Fig. 2.5 required dimensions

Table of measurements:

Dimension	A	B	C	D	E	F
Dimension in (mm)						

4. Vernier Calipers

The Vernier caliper is a measuring instrument with a sliding scale used to carry out accurate measurements of inside, outside, and depth dimensions as will be shown in the following figures.

4.1 The accuracy of Vernier calipers

The Vernier caliper consists of a main scale engraved on a fixed ruler and a Vernier scale engraved on a movable jaw. The movable Vernier scale is free to slide along the length of the fixed ruler. The main scale is presented in centimeters with the smallest division in millimeters. According to the number of divisions, the accuracy values are determined as follows:

1. The Vernier caliper with **10** divisions in **Vernier scale** is accurate to $(\pm 1/10) = \pm 0.1$ mm.
2. The Vernier caliper with **20** divisions in **Vernier scale** is accurate to $(\pm 1/20) = \pm 0.05$ mm.
3. The Vernier caliper with **50** divisions in **Vernier scale** is accurate to $(1/50) \pm 0.02$ mm.

4.2 Main parts of the Vernier caliper

The Vernier caliper has six main parts as illustrated in Fig. 2.6;

1. **External jaws**: used to measure external lengths.
2. **Internal jaws**: used to measure internal lengths.
3. **Stem**: used to measure depths.
4. **Main scale**
5. **Vernier scale**
6. **Screw clamp**: used to block the movable jaw to allow the easy transferring a measurement.

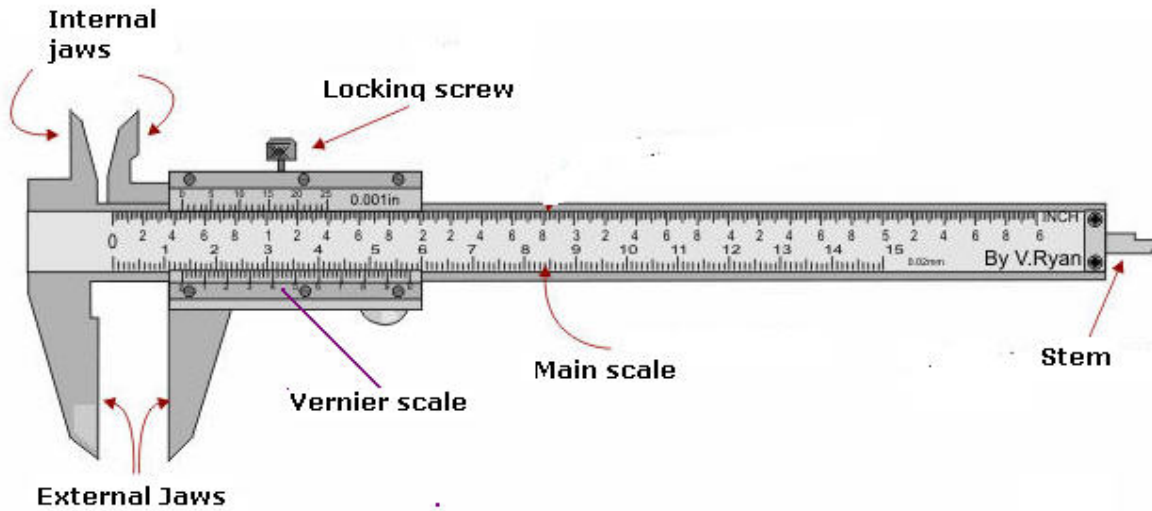
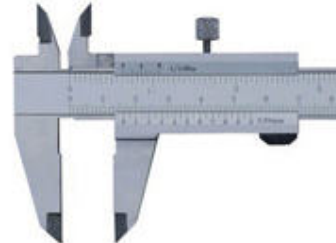

Fig.2.6 main parts of Vernier caliper

4.3 Types of Vernier calipers

There are three kinds of Vernier calipers in the market as shown in the figures below

a- **Standard** Vernier caliper



Standard

b- **Dial** Vernier caliper



Dial

c- **Digital** Vernier caliper



Digital

4.4 Using Vernier Calipers

Vernier calipers can be used to perform the following measurements:

1. The outside diameter or width of an object.



Measuring outside diameter

2. The inside diameter or width of an object.



Measuring inside diameter

3. The depth of an object.



Measuring depth

4.5 Reading Vernier Calipers

The Vernier scale that is shown in the Fig. 2.7 below is divided into 10 equal divisions and thus the least count of the instrument is 0.1 mm. Both the main scale and the Vernier scale readings are taken into account when measuring. The main scale reading is the first reading on the main scale immediately to the left of the **zero** of the Vernier scale, which in this case is (3 mm). While the Vernier scale reading is the mark on the Vernier scale, which exactly coincides with a mark on the main scale (0.7 mm). The reading therefore will be $3\text{mm} + 0.7\text{ mm} = 3.7\text{ mm}$

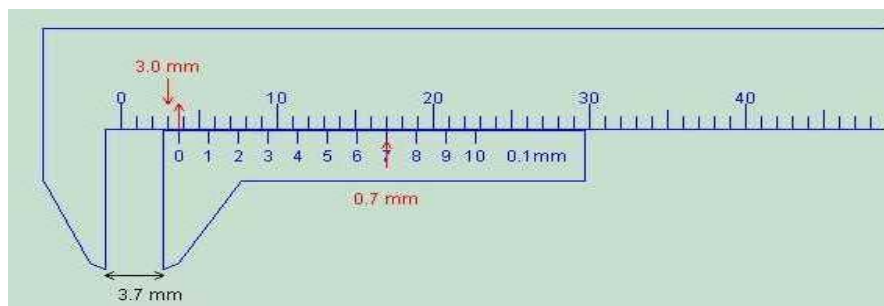
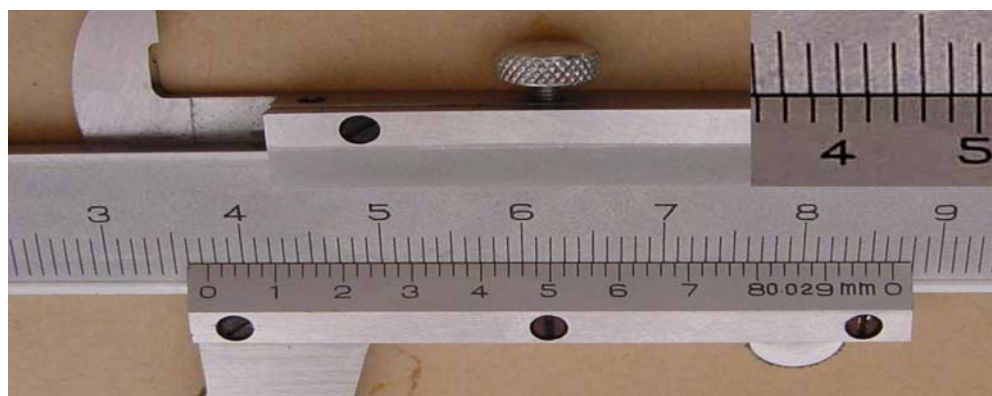

Fig.2.7 Showing the vernier caliper reading

4.6 Examples of Vernier caliper reading:

Enlarged view



The reading is: $37\text{ mm} + 0.46\text{ mm} = 37.46\text{ mm}$.

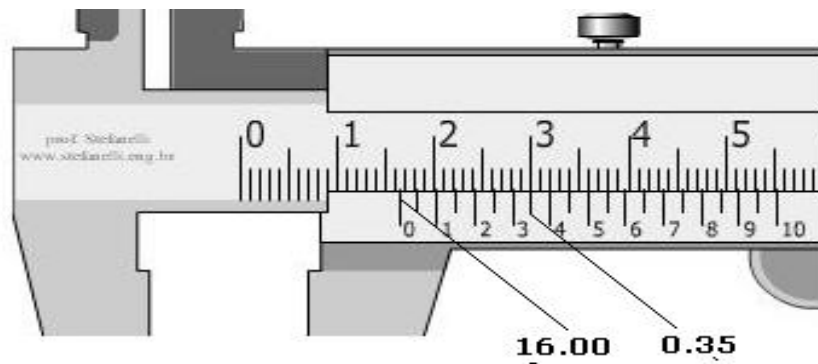

The reading is: 16 mm + 0.35 mm = 16.35 mm

For further reading, you can use the following links:

- 1- [Reading vernier caliper 1](#)
- 2- [Online test](#)

5. Practical Task 2

You will be given a drill chuck as the one shown in Fig. 2.10. Use the Vernier caliper to measure the indicated dimensions 1 to 7 and record your readings in the table below.

Note: You need to use a Vernier caliper of an accuracy of 0.03 mm.

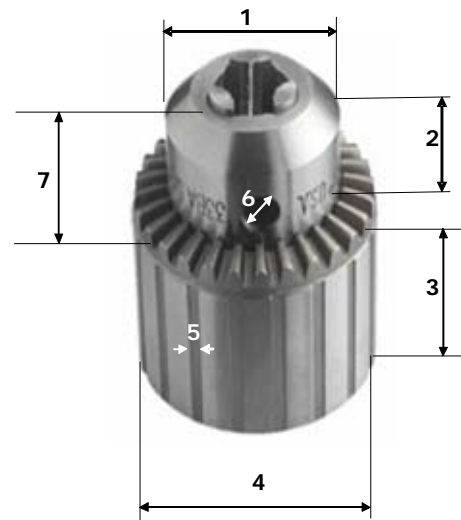

Fig. 2.8 Drill chuck

Number	1	2	3	4	5	6	7
Dimension (mm)							

6. Micrometers

The micrometer screw gauge is used to measure even smaller dimensions than the Vernier calipers. The micrometer screw gauge also uses an auxiliary scale (measuring hundredths of a millimeter) which is marked on a rotary thimble. It is a screw with an accurately constant pitch. The micrometers in our laboratory have a pitch of 0.01 mm (two full turns are required to close the jaws by 1.00 mm). The rotating thimble is subdivided into 50 equal divisions. The thimble must be rotated through two revolutions to open the jaws by 1 mm.

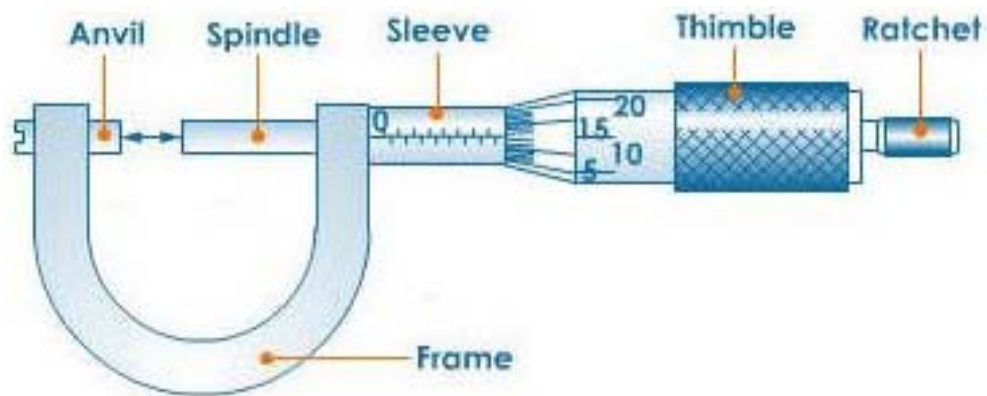

Fig.2.9: The micrometer

6.1 Reading the micrometer:

Steps of reading the micrometer:

The following steps are used in order to obtain an accurate micrometer reading

- a- Note the whole number of mm divisions on the sleeve (major divisions); which is 10mm in Figure 2.10 below.
- b- Observe whether there is a half mm visible or not; which is 0.5mm in Figure 2.10 below.
- c- Finally read the line on the thimble coinciding with the datum line; which is 0.33mm in Figure 2.10 below.

Step 1: read the whole millimeters on the sleeve, the value in this example is 6mm

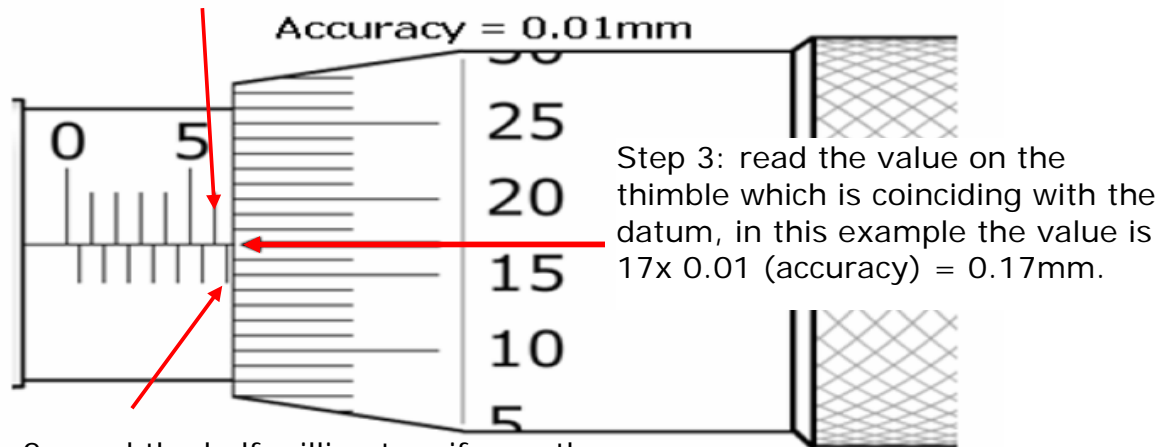

Step 2: read the half millimeters if any, the value could be either 0.5mm or 0.0 mm, in this example is the value is 0.5 mm

Figure 2.10 Reading the micrometer

Step 4: add the three values obtained from steps 1, 2, and 3 together to find the reading $6+0.5+0.17=6.67$ mm

6.2 Examples of micrometer reading:

The reading in the adjacent figure is:

$$5.5\text{mm} + 0.22\text{mm} = 7.72\text{mm}$$



The reading in the adjacent figure is:

$$7\text{mm} + 0.38\text{mm} = 7.38\text{mm}$$



7. Practical Task 3:

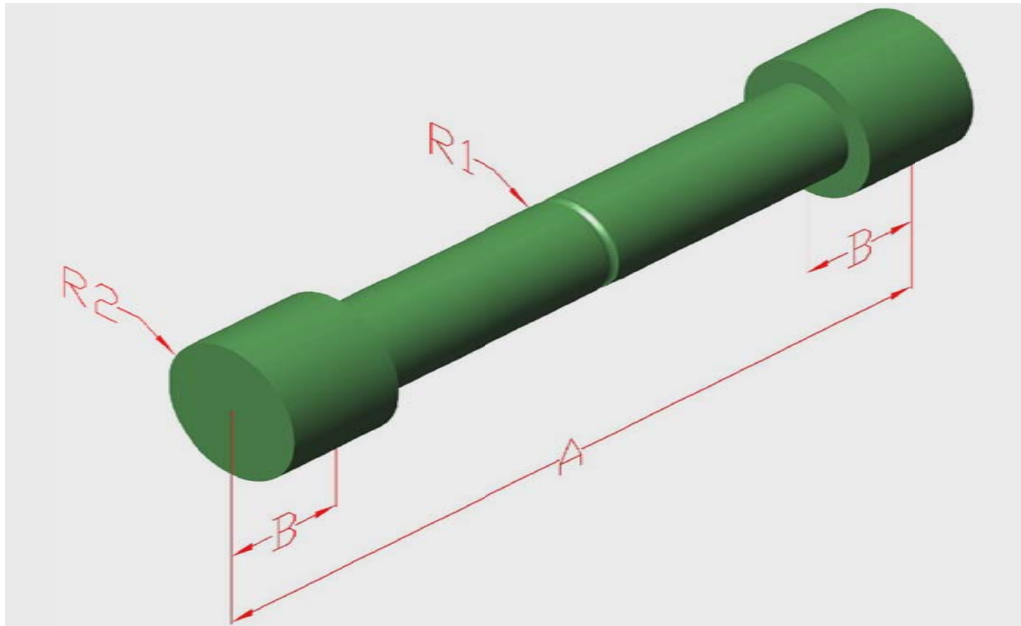

You will be given a work-piece similar to the one shown below in Fig.2.11. Use the micrometer and the Vernier caliper to measure the indicated dimensions. Record your measurements in the table below



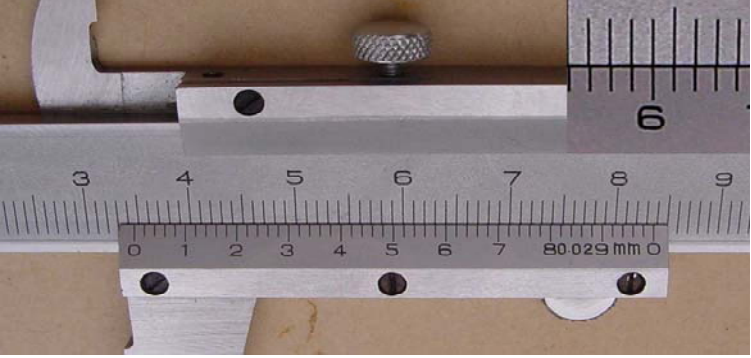

Indicated Dimension	R1	R2	A	B
Reading in (mm)				

Review Questions

Find the reading of the following vernier calipers

Reading	Vernier caliper
<p>.....</p>	 <p>A vernier caliper is shown measuring a cylindrical object. The main scale is graduated in millimeters, with markings every 1 mm and sub-markings every 0.5 mm. The vernier scale is graduated in millimeters, with markings every 0.1 mm. The zero of the vernier scale is aligned with the 4.5 mm mark on the main scale. The 10th vernier mark is aligned with the 5.0 mm mark on the main scale.</p>
<p>.....</p>	 <p>A vernier caliper is shown measuring a cylindrical object. The main scale is graduated in millimeters, with markings every 1 mm and sub-markings every 0.5 mm. The vernier scale is graduated in millimeters, with markings every 0.1 mm. The zero of the vernier scale is aligned with the 5.5 mm mark on the main scale. The 10th vernier mark is aligned with the 6.0 mm mark on the main scale.</p>
<p>.....</p>	 <p>A vernier caliper is shown measuring a cylindrical object. The main scale is graduated in millimeters, with markings every 1 mm and sub-markings every 0.5 mm. The vernier scale is graduated in millimeters, with markings every 0.1 mm. The zero of the vernier scale is aligned with the 6.5 mm mark on the main scale. The 10th vernier mark is aligned with the 7.0 mm mark on the main scale.</p>

Reading	Micrometer
<p>.....</p>	 <p>A close-up photograph of a micrometer's scale. The main scale shows 0 mm and 5 mm. The sleeve has a horizontal line aligned with the 5 mm mark. The thimble scale shows 0, 5, 10, and 15. The horizontal line of the sleeve is aligned with the 5th mark on the thimble scale.</p>
<p>.....</p>	 <p>A close-up photograph of a micrometer's scale. The main scale shows 0 mm and 5 mm. The sleeve has a horizontal line aligned with the 3 mm mark. The thimble scale shows 25, 30, 35, and 40. The horizontal line of the sleeve is aligned with the 5th mark on the thimble scale.</p>
<p>.....</p>	 <p>A close-up photograph of a micrometer's scale. The main scale shows 0 mm and 5 mm. The sleeve has a horizontal line aligned with the 1 mm mark. The thimble scale shows 5, 10, and 15. The horizontal line of the sleeve is aligned with the 10th mark on the thimble scale.</p>