

UNIT

4

Measuring Prisms and Cylinders

Most products are packaged in boxes or cans. Think about how a box or can is made. How do you think the manufacturer chooses the shape and style of package? Why do you think tennis balls are sold in cylinders but golf balls are sold in rectangular prisms?

Look at the packages on these pages. Choose one package. Why do you think the manufacturer chose that style of packaging?

What You'll Learn

- Draw and construct nets of 3-D objects.
- Determine the surface areas of prisms and cylinders.
- Develop formulas for the volumes of prisms and cylinders.
- Solve problems involving prisms and cylinders.

Why It's Important

- We need measurement and calculation skills to design and build objects to meet our needs.
- Calculating the surface area and volume of prisms and cylinders is an extension of the measuring you did in earlier grades.





Key Words

- net
- polyhedron
- regular prism
- regular pyramid
- regular dodecagon
- surface area
- volume
- capacity

4.1

Exploring Nets

Focus Identify, draw, and construct nets of objects.

Suppose this diagram was cut out and folded along the dotted lines to make an object.

Which object do you think would be made?
Why do you think so?

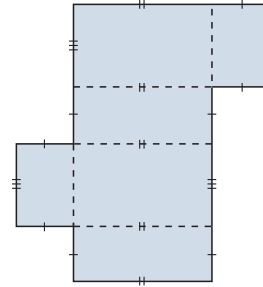

Investigate

Work in groups of 3.

You will need 3 different objects, one for each group member, scissors, tape, and markers.

Name each face of your object.

Label each face with a letter.

- ▶ Trace each face of the object.
Label each tracing with its letter.
- ▶ Cut out your tracings.
Tape them together at the edges to make a diagram.
Arrange the faces so the diagram can be folded to build a model of your object.
- ▶ Fold the diagram to build the model.
- ▶ How many different ways can you make a diagram to form the model?
- ▶ Trade diagrams with another group member.
Check that each diagram folds to build the model.



Reflect & Share

Share your objects and diagrams with another group of classmates.
How did you decide how to arrange the faces?
How are the diagrams for the prisms different?
How are they alike?



Connect

A **net** is a diagram that can be folded to make an object.
A net shows all the faces of an object.

A net can be used to make an object called a **polyhedron**.

A polyhedron has faces that are polygons.

Two faces meet at an *edge*.

Three or more edges meet at a *vertex*.

- A *prism* has 2 congruent bases and is named for its bases.

When all its faces, other than the bases, are rectangles and they are perpendicular to the bases, the prism is called a **right prism**.

Here is a right pentagonal prism and its net.

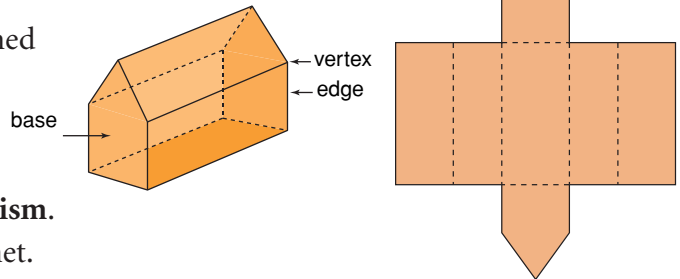

A **regular prism** has regular polygons as bases.

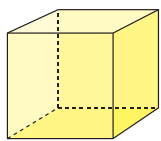

cube

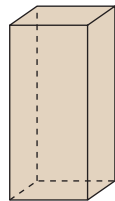

square prism

A **regular pyramid** has a regular polygon as its base. Its other faces are triangles.

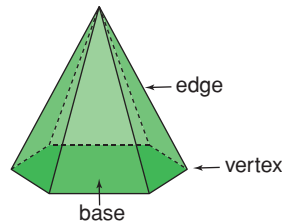

regular hexagonal pyramid

A regular polygon has all sides equal and all angles equal.

- Here is a right cylinder and its net.

The line joining the centres of the circular bases is perpendicular to the bases.

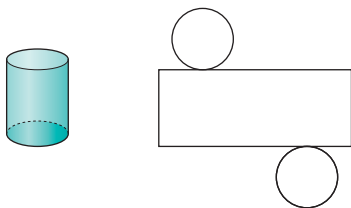

The two congruent circles are on opposite sides of the rectangle.

Example 1

Which diagram is the net for this right square prism?

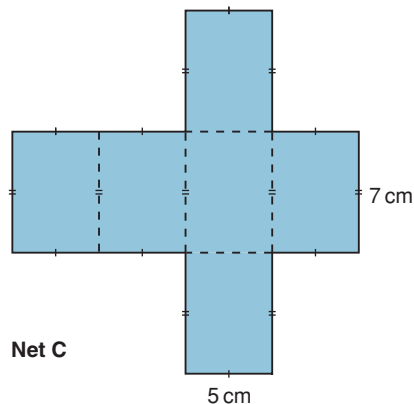
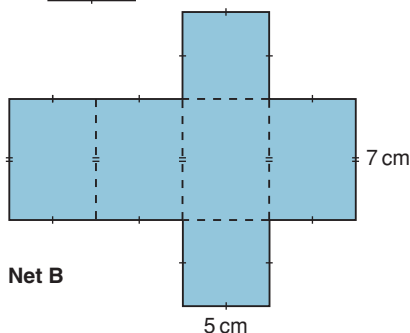
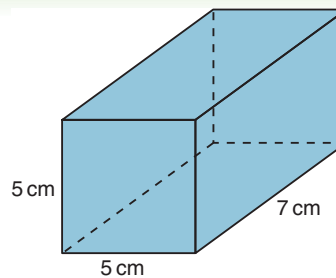
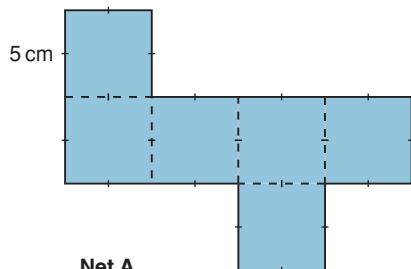

► A Solution

This square prism has 2 square bases and 4 rectangular faces that are not squares.

Net A has 6 square faces, so it is not the correct net.

Net B has 2 square faces and 4 rectangular faces, so it is the correct net.

Net C has all rectangular faces, so it is not the correct net.

Example 2

Use a ruler and compass.

Construct a net of this right triangular prism.

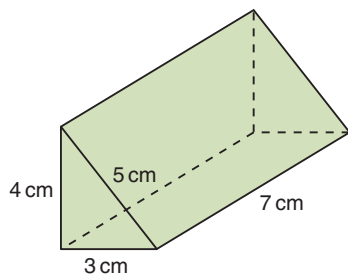

► A Solution

The prism has 2 congruent triangular bases and 3 rectangular faces.

Sketch the net of the triangular prism.

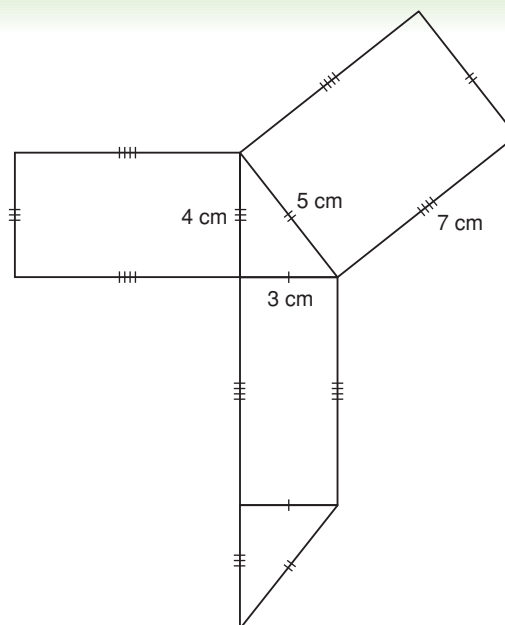

Construct the net of the prism.

- ▶ Start by constructing a base, $\triangle ABC$.
Use a ruler to draw $BC = 3$ cm.
With the compass point and pencil 5 cm apart, put the compass point on C and draw an arc.
With the compass point and pencil 4 cm apart, put the compass point on B and draw an arc.
Mark point A where the arcs intersect.
Join AB and AC.
Label each side with its length.

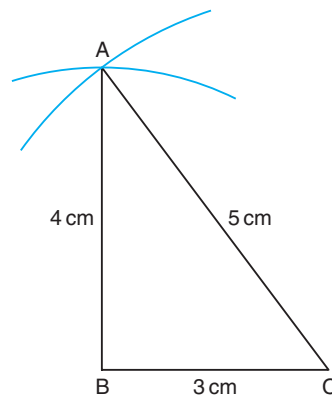

- ▶ Use what you know about parallel and perpendicular lines to:
 - Construct a rectangle on AB with length 7 cm.
 - Construct a rectangle on AC with length 7 cm.
 - Construct a rectangle on BC with length 7 cm.
 - Construct a triangle congruent to $\triangle ABC$ on the rectangle on BC.

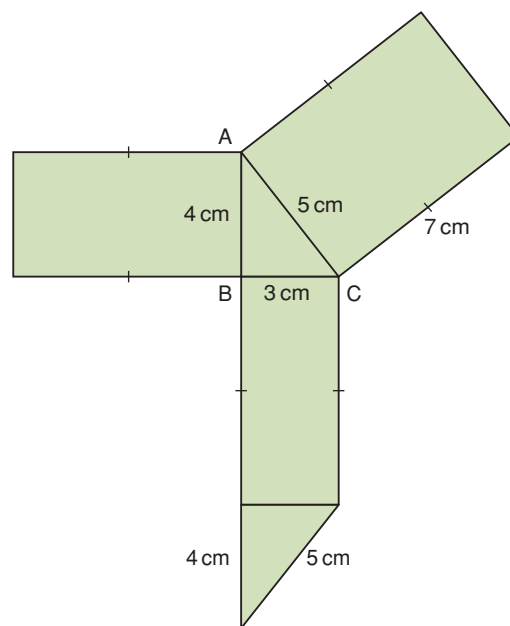

Discuss the ideas

1. Look at the net of a cylinder in *Connect*. Does it matter where the circles are placed along the sides of the rectangle? Justify your answer.
2. In *Example 2*, the base of the right prism is a right triangle. What other types of triangles could be the base of a right prism? How would you name each prism?
3. Why is it useful to be able to draw nets?

Practice

Check

4. Use square dot paper. Draw a net of this right rectangular prism. Identify and name each face.

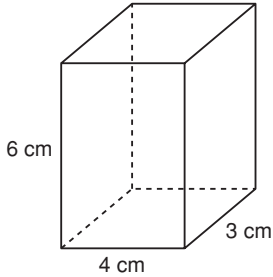

5. Use square dot paper. Draw a net of this cube. Identify and name each face.

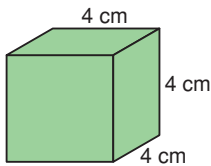

6. One diagram below is the net of this object. Choose the correct net. Justify your choice.

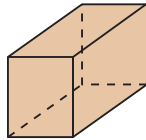

a)

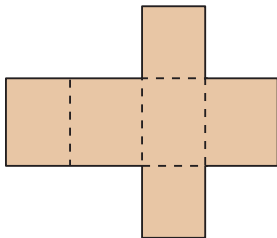

b)

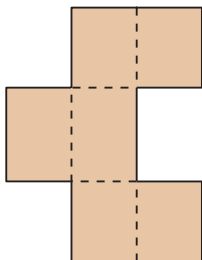

7. Use square dot paper. Draw a net of this square prism. Identify and name each face.

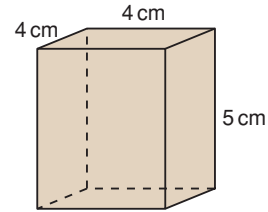

Apply

8. Construct a net of this right isosceles triangular prism. Identify and name each face.

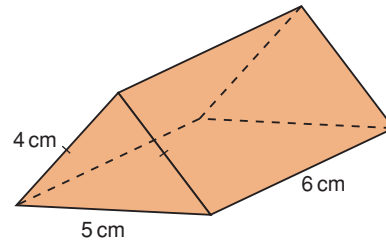

9. a) Match each object to its net.
b) Identify and name each face of each object.

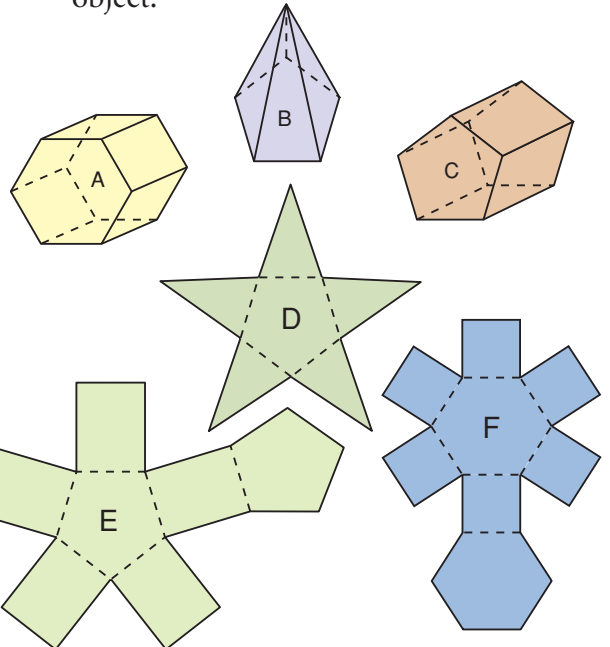

10. Which of the diagrams below are nets of a square pyramid? Justify your choices.

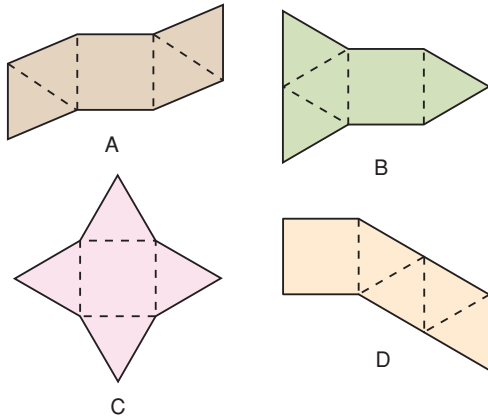

11. The Saamis Teepee in Medicine Hat, Alberta is shaped like a dodecagonal pyramid. Which diagram below is a net for a regular dodecagonal pyramid? How do you know?



A regular dodecagon is a polygon with 12 equal sides and 12 equal angles.

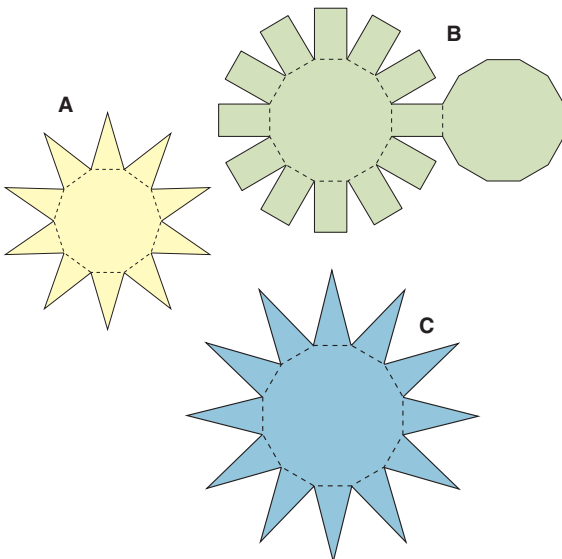

12. Assessment Focus

Name each object and identify its faces. Draw or construct as many different nets as you can for each object. Use square dot paper or triangular dot paper if it helps. Use hatch marks to show which sides have the same length.

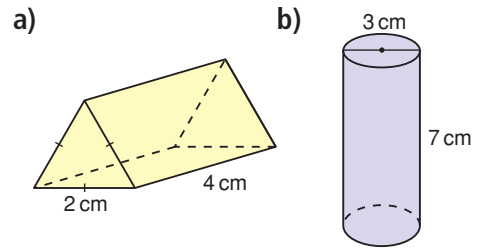

13. The sums of the numbers on opposite faces of a die are equal.

- a) Copy each net onto grid paper. Label each face with a number from 1 to 6, so the net can fold to make a die.

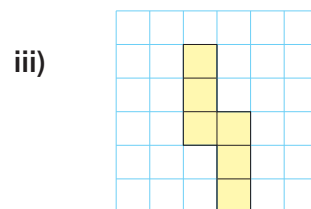
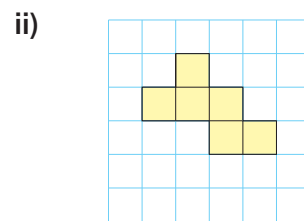
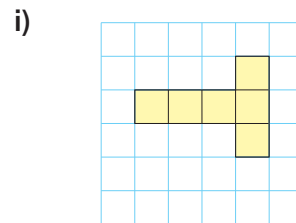

- b) Draw a different net of a die. Label its faces.

14. Use the descriptions below. Identify an object that has each set of faces.

- a) four equilateral triangles and one square
- b) two congruent squares and four congruent rectangles
- c) one rectangle and two pairs of congruent triangles
- d) five congruent triangles and one regular pentagon
- e) four congruent equilateral triangles

15. Take It Further Decorative wrapping paper is often used to wrap a gift. How is wrapping paper similar to a net? How is it different?

16. Take It Further You will need triangular dot paper.

- a) A triangular pyramid with all faces congruent is a regular tetrahedron. Draw all possible nets for a regular tetrahedron.
- b) Draw all possible nets for a pyramid with an equilateral triangular base and three isosceles triangular faces.
- c) Compare your nets in parts a and b. Explain any differences.

17. Take It Further

Rubik's cube, a popular and challenging puzzle, is made of 27 small cubes.

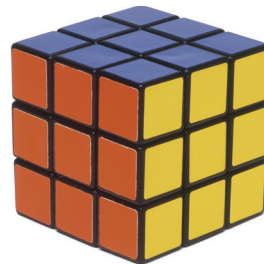

- a) Draw a net of one of the small cubes. Indicate which cube you are drawing and label each face you see.
- b) Draw a net of the Rubik's cube. Label each face you see.
- c) How are the nets in parts a and b alike? How are they different?
- d) The Rubik's cube was turned and twisted. How would you change the net you drew in part b to reflect the changes shown?



Reflect

Choose a package in the shape of a polyhedron.

Sketch the package. Include appropriate dimensions.

Cut along the edges to make the net.

Why do you think the manufacturer used this shape for the package?

Can you find a better shape? Explain.

4.2

Creating Objects from Nets

Focus Build objects from nets.

In Vincent Massey Junior High School in Calgary, Grade 8 students taking Fashion Studies work with a pattern to make a pair of pyjama pants. How is a pattern similar to a net? How is it different?

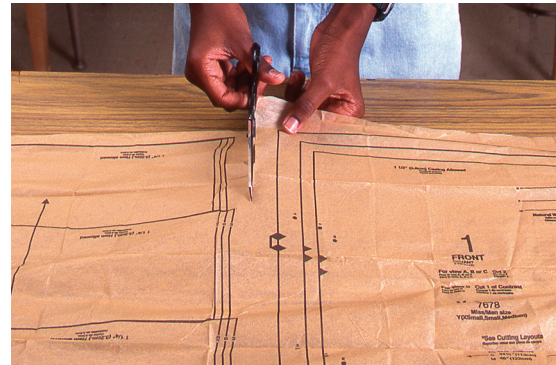

Investigate

Work with a partner.
You will need scissors and tape.
Your teacher will give you large copies of the nets below.

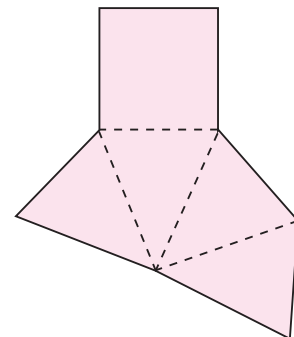
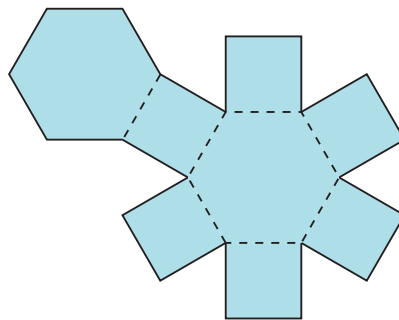
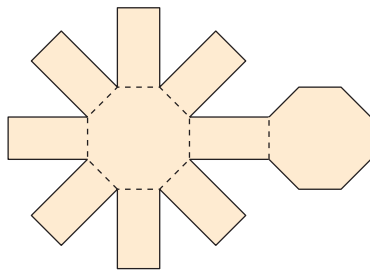

- Predict the object that can be formed from each net above.
- Use a copy of each net.
Fold, then tape the net to verify your prediction.

Reflect & Share

Compare the three objects you made with those of another pair of classmates. What do you notice? What does this tell you about nets of different objects?

Connect

To determine if a diagram is a net for an object, look at each shape and at how the shapes are arranged.

- This is *not* a net for a rectangular prism.
If this diagram was folded, it would form a box that is open at one end.
At the opposite end, two rectangles would overlap.

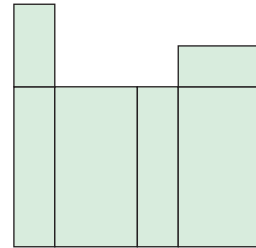

Example 1

Look at the diagrams below.

Is each diagram the net of an object?

If your answer is yes, name and describe the object.

If your answer is no, what changes could you make so it could be a net?

a)

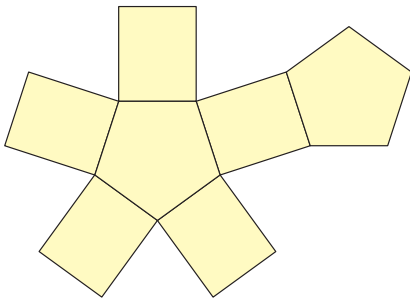

b)

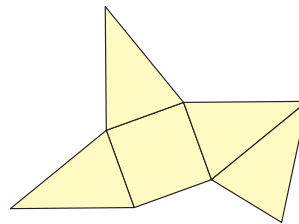

c)

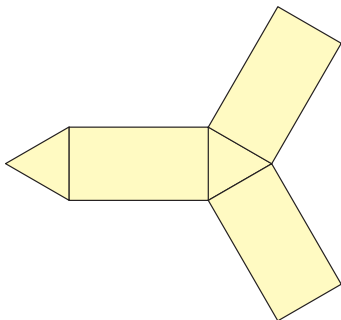

d)

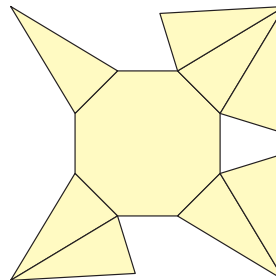

► A Solution

- a) This diagram has 2 congruent regular pentagons and 5 congruent rectangles.
When it is folded, congruent sides join to form edges.
The diagram is a net of a right pentagonal prism.

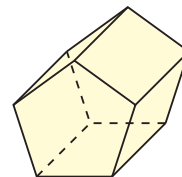

- b) This diagram has 1 square and 4 congruent isosceles triangles. The diagram is a net of a square pyramid.



- c) This diagram has 2 congruent equilateral triangles and 3 congruent rectangles. The diagram is a net of a right triangular prism. It has equilateral triangular bases.

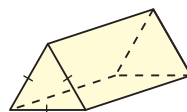

- d) This diagram is not a net. When it is folded, 2 triangular faces overlap, and the opposite face is missing. To make a net, move one triangular face from the top right to the top left. The diagram is now a net of an octagonal pyramid.

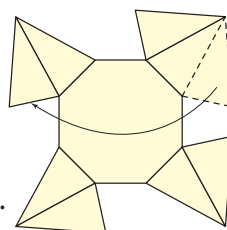

Example 2

- Predict the object this net will form.
- Fold a copy of the net to verify your prediction.
- Describe the object.

A Solution

- The net has one regular hexagon and 6 congruent triangles. So, the net probably makes a hexagonal pyramid.
- When the net is folded, it forms a hexagonal pyramid.
- The object is a polyhedron because its faces are polygons. The object is a regular hexagonal pyramid. This means that the base of the pyramid is a regular hexagon. The pyramid has 6 congruent triangular faces.

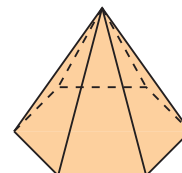
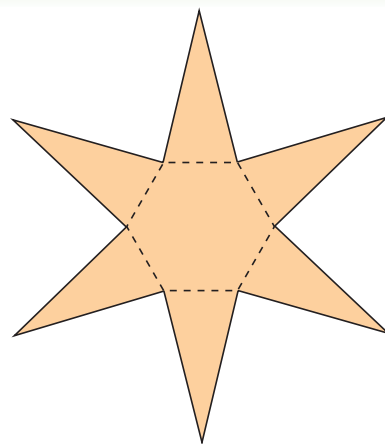

Discuss the ideas

1. How can you tell whether a given net is for a prism or a pyramid?
2. How can you change the net in *Connect* to create a net of a rectangular prism?
How many different ways can you do this?

Practice

Check

Your teacher will give you a large copy of each net.

3. One diagram below is the net of a right cylinder. Predict which diagram is a net. Cut out the diagrams. Fold them to confirm your prediction.

a)

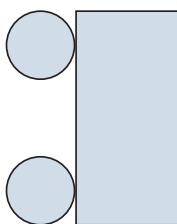

b)

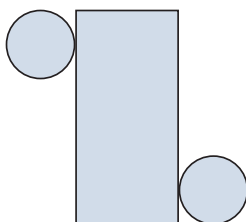

4. a) Predict the object this net will form.
b) Fold the net to verify your prediction.
c) Describe the object.

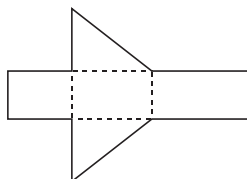

5. a) Predict the object in Set B that each net in Set A will form.
b) Fold each net to verify your prediction.

Set A

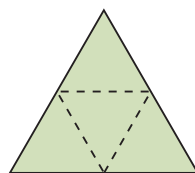

Net C

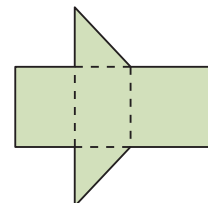

Net D

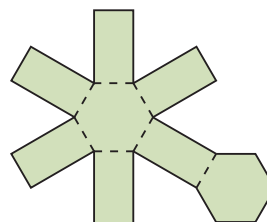

Net E

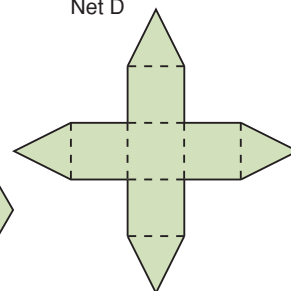

Net F

Set B

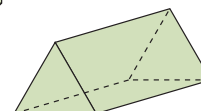
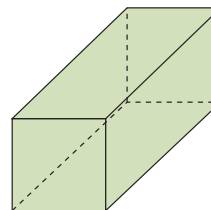
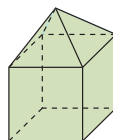
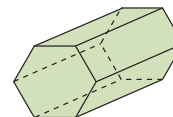
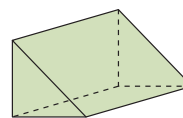

Apply

6. a) Describe the object this net will form.
 b) Fold the net to verify your prediction.
 c) Is the object a polyhedron? If it is, describe the polyhedron.
 d) Identify parallel faces and perpendicular faces.

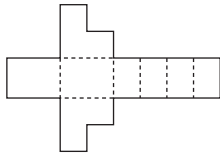

7. Assessment Focus

- a) Is this diagram a net of a right octagonal prism? If your answer is yes, tell how you know.
 b) If your answer is no, describe and sketch any changes you would make to correct the diagram. How many different ways could you correct the diagram? Explain.

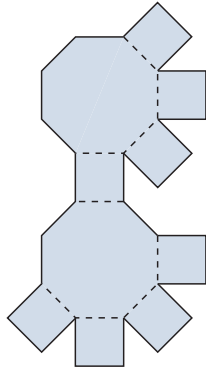

8. A soccer ball is not a sphere. It is a polyhedron. Explain which polygons are joined to make the ball. How are the polygons joined?



9. Which diagrams are nets?
 How do you know?
 For each net, identify and describe the object it will form.
 Verify your answer.
 Explain how you did this.

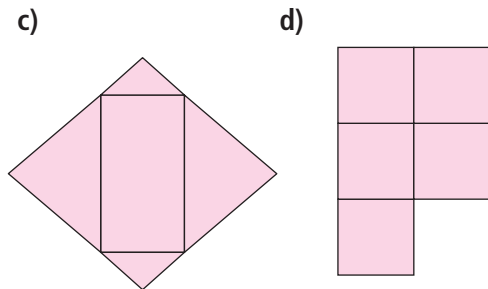
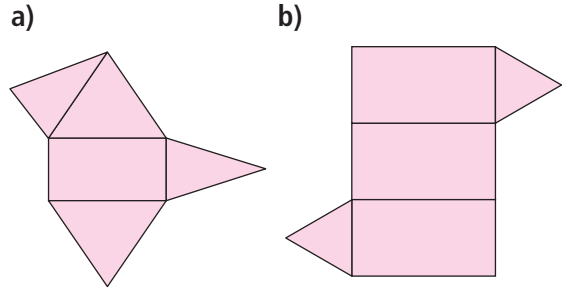

10. One diagram below is the net of this decagonal pyramid. Predict which diagram is a net.
 Cut out the diagrams.
 Fold them to confirm your prediction.

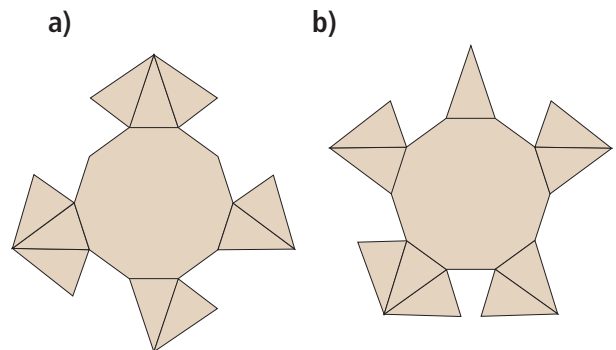
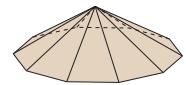

11. Which diagrams below are nets of a cube? Explain how you know.

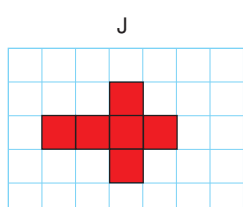
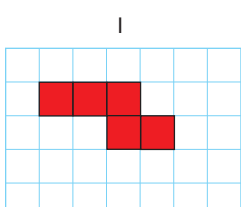
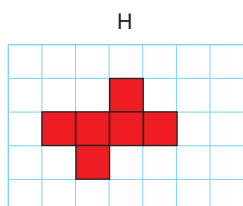
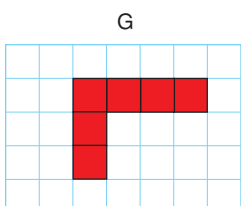
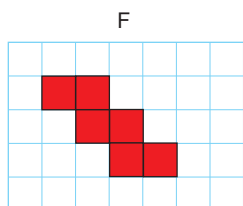
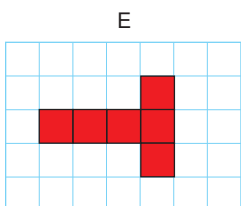
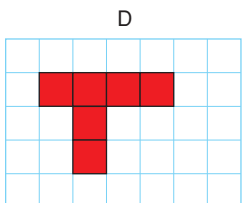
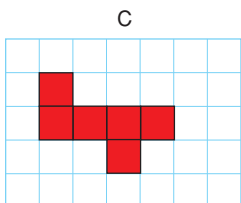
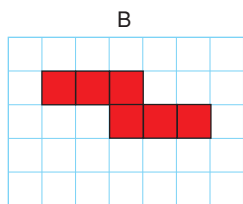
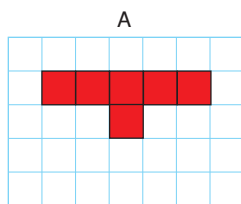

12. **Take It Further** Fold 2 of these nets to make 2 square pyramids with no base.

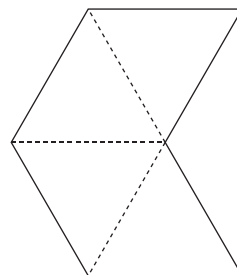

Tape the 2 pyramids together at their missing bases. You have made a regular octahedron.

- Why does it have this name?
- Describe the octahedron.
How do you know it is regular?

13. **Take It Further**

- Fold this net to make an object. Describe the object.

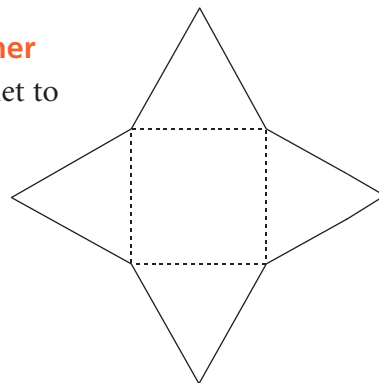

- Suppose the object in part a is cut and part of it is removed to form the object below. What changes would you make to the net so that it folds to make the new object? Show your work.

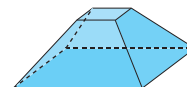

Reflect

When you see a diagram that may be a net of an object, how do you find out if it is a net? Include an example in your explanation.

4.3

Surface Area of a Right Rectangular Prism

Focus

Find the surface area of a right rectangular prism.

This rectangular prism is made from 1-cm cubes.
What is the surface area of the prism?

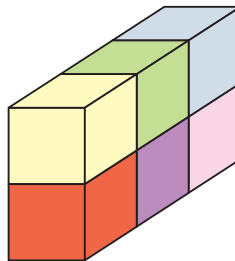

Investigate

Work with a partner.

You will need an empty cereal box, scissors, and a ruler.

- Open the bottom of the box without tearing the edges. Then cut along one edge to make a net.
- Find the area of the net. What measurements did you make?
- Did you find any shortcuts? Explain. How does the area of the net relate to the area of the surface of the cereal box?
- Describe a method to find the area of the surface of any right rectangular prism.



Reflect & Share

Compare your method with that of another pair of classmates.
How were your methods similar?
How were they different?
Do both methods work? How could you check?

Connect

Here is a right rectangular prism and its net.

The net has 6 rectangles,
labelled A to F.

The area of the net is the sum of
the areas of the 6 rectangles.

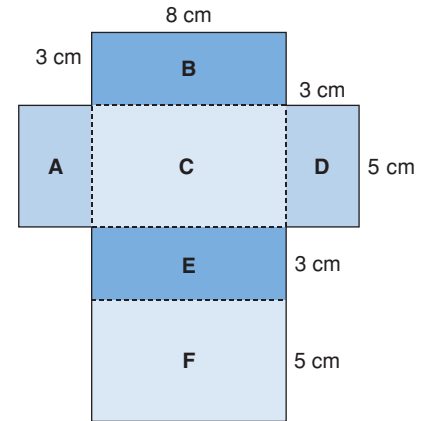
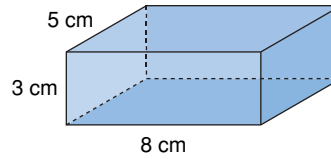

$$\begin{aligned}
 \text{The area of the net} &= \text{area of Rectangle A} + \text{area of Rectangle B} \\
 &\quad + \text{area of Rectangle C} + \text{area of Rectangle D} \\
 &\quad + \text{area of Rectangle E} + \text{area of Rectangle F} \\
 &= (3 \times 5) + (8 \times 3) + (8 \times 5) + (3 \times 5) \\
 &\quad + (8 \times 3) + (8 \times 5) \\
 &= 15 + 24 + 40 + 15 + 24 + 40 \\
 &= 158
 \end{aligned}$$

The area of the net is 158 cm^2 .

We say that the **surface area** of the rectangular prism is 158 cm^2 .

The surface area of an object is the sum of the areas of its faces.

We can use the net of a rectangular prism to find its surface area.

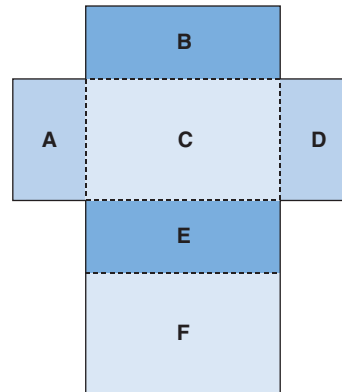
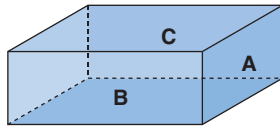

There are 3 pairs of congruent rectangles in the net
of a rectangular prism.

So, we can write the surface area a shorter way.

$$\begin{aligned}
 \text{Surface area} &= 2 \times \text{area of Rectangle A} \\
 &\quad + 2 \times \text{area of Rectangle B} \\
 &\quad + 2 \times \text{area of Rectangle C}
 \end{aligned}$$

Example 1

Find the surface area of this right rectangular prism.

▶ A Solution

Identify each rectangle with a letter.

Rectangle A has area: $15 \times 8 = 120$

Rectangle B has area: $15 \times 10 = 150$

Rectangle C has area: $8 \times 10 = 80$

So, surface area = $2(120) + 2(150) + 2(80)$

$$= 240 + 300 + 160$$

$$= 700$$

The surface area of the rectangular prism is 700 cm^2 .

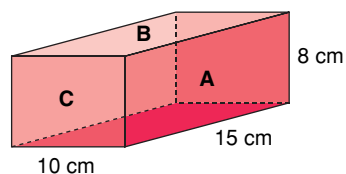
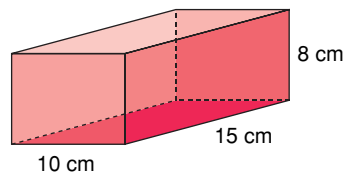

Example 2

The school is holding elections for student council.

The ballot box is to be painted.

The ballot box is a cube with edge length 30 cm.

There is a slot on the top.

The slot has length 16 cm and width 1 cm.

What is the total surface area to be painted?

Assume the base is to be painted.

▶ A Solution

Draw a labelled picture.

The cube has 6 congruent square faces.

Each face has area: $30 \text{ cm} \times 30 \text{ cm} = 900 \text{ cm}^2$

So, the surface area of the cube is:

$$6 \times 900 \text{ cm}^2 = 5400 \text{ cm}^2$$

The area of the slot is: $16 \text{ cm} \times 1 \text{ cm} = 16 \text{ cm}^2$

The surface area of the ballot box is:

$$\text{Surface area of cube} - \text{area of slot} = 5400 \text{ cm}^2 - 16 \text{ cm}^2$$

$$= 5384 \text{ cm}^2$$

The surface area to be painted is 5384 cm^2 .

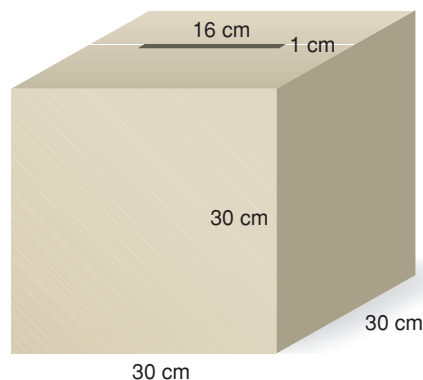

Discuss

the ideas

1. Explain how the net of a rectangular prism can help you find the surface area of the prism.
2. Suppose the rectangular prism in *Example 1* was open at the top. How would this affect its surface area?
3. In *Example 2*, suppose it was decided not to paint the base. What is the total surface area to be painted?

Practice

Check

4. Here is the net of a right rectangular prism. The area of each face is given. What is the surface area of the prism? How did you find out?

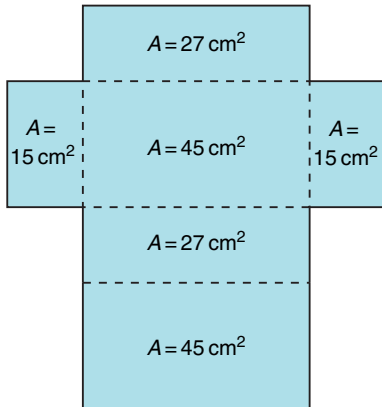

5. Sketch a net of this right rectangular prism. What is its surface area?

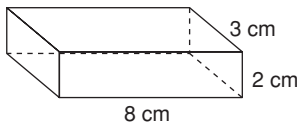

6. Find the surface area of each right rectangular prism.

a)

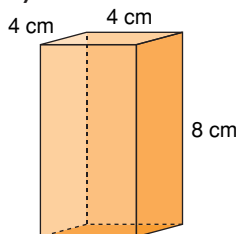

b)

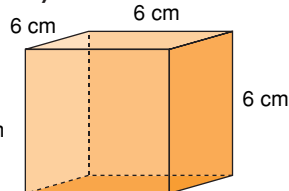

c)

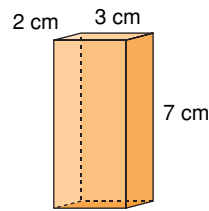

7. Find the surface area of a right rectangular prism with these dimensions.

- a) 4 m by 3 m by 10 m
- b) 3 cm by 5 cm by 8 cm

Apply

8. Find a right rectangular prism in the classroom. Measure its faces. Find its surface area.
9. Tanya paints the walls of her family room. The room measures 7 m by 4 m by 3 m. The walls need 2 coats of paint. A 4-L can of paint covers 40 m^2 .
- a) How much paint should Tanya buy?
 - b) What assumptions do you make? Explain.
10. The surface area of a cube is 54 cm^2 .
- a) What is the area of one face of the cube?
 - b) What is the length of one edge of the cube?

11. A window washing company is hired to wash the windows in a condominium. The building is 50 m by 30 m by 300 m. Windows cover about one-quarter of the building. What is the total surface area of the windows to be washed? What assumptions do you make?

12. The Sandberg Institute building in Amsterdam generates revenue by selling advertising space on the exterior of the building. The building is a rectangular prism with dimensions 50 m by 40 m by 75 m. Suppose it costs 1 Euro per month to rent an advertising space of 50 cm^2 . Each of the 4 walls of the building is covered with advertisements. How much money will the institute earn in one month?

13. Which prism has the greatest surface area? The least surface area?

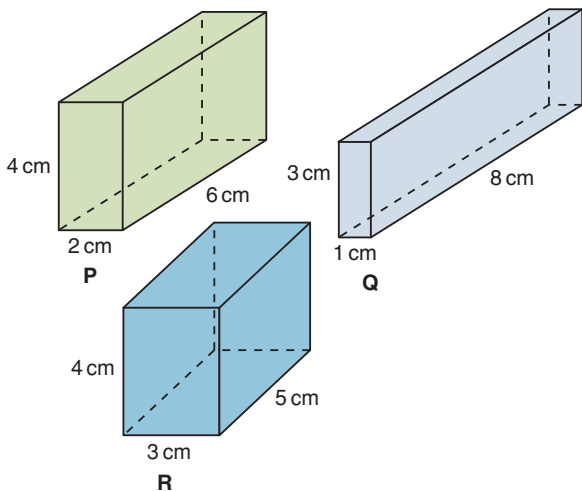

14. Assessment Focus Sketch a right rectangular prism. Label its dimensions. Answer the question below. Justify your answer. What do you think happens to the surface area of a prism in each case?

- i) Its length is doubled.
- ii) Its length is halved.

15. Each object has the shape of a rectangular prism, but one face or parts of faces are missing. Find each surface area.

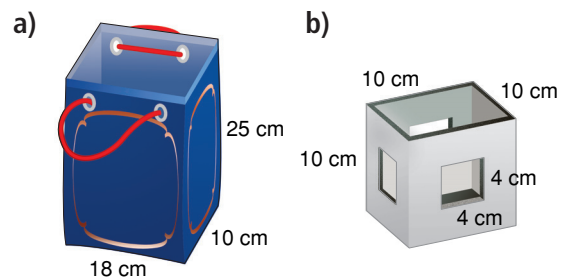

16. Take It Further A right rectangular prism has a square base with area 4 m^2 . The surface area of the prism is 48 m^2 . What are the dimensions of the prism?

17. Take It Further A right rectangular prism has faces with these areas: 12 cm^2 , 24 cm^2 , and 18 cm^2 . What are the dimensions of the prism? How did you find out?

Reflect

Explain how you would find the surface area of a rectangular prism. Include a diagram in your explanation. How does a net help you find the surface area?

4.4

Surface Area of a Right Triangular Prism

Focus Find the surface area of a right triangular prism.

What is the area of this rectangle?

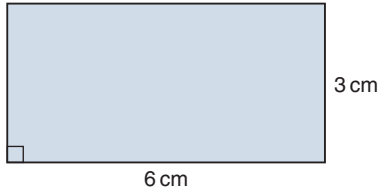

What is the area of this triangle?

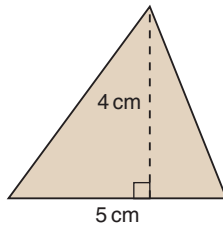

You will use these measures to find the surface area of a right triangular prism.

Investigate

Work with a partner.

Your teacher will give you a right triangular prism.

- Find the surface area of the triangular prism.
- Describe your strategy for finding the surface area of the prism.
- Do you think your strategy would work for any prism? Trade prisms with a pair of classmates who used a different prism. Use your strategy to find its surface area.

Reflect & Share

Compare your strategy and results with the same pair of classmates.

Did you use the same strategy?

If not, do both strategies work? Explain.



Connect

A right triangular prism has 5 faces: 3 rectangular faces and 2 triangular bases.

The two triangular bases of the prism are congruent.

Here is a triangular prism and its net.

The measurements are given to the nearest centimetre.

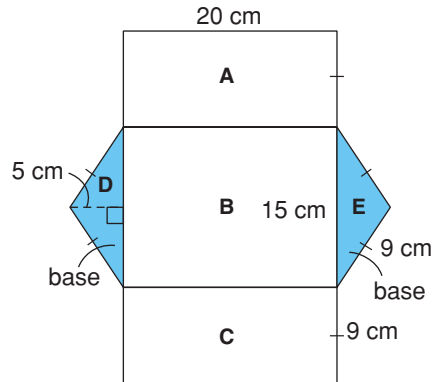
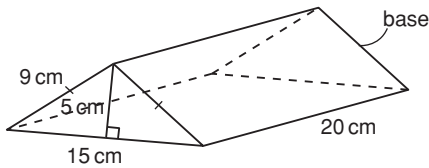

The surface area of a triangular prism is the sum of the areas of its faces.

Rectangle A has area: $20 \times 9 = 180$

Rectangle B has area: $20 \times 15 = 300$

Rectangle C has area: $20 \times 9 = 180$

Triangle D has area: $\frac{1}{2} \times 15 \times 5 = \frac{75}{2} = 37.5$

Triangle E has area: $\frac{1}{2} \times 15 \times 5 = \frac{75}{2} = 37.5$

The area measurements are approximate because the measurements are given to the nearest centimetre.

Surface area = area of Rectangle A + area of Rectangle B + area of Rectangle C

+ area of Triangle D + area of Triangle E

= $180 + 300 + 180 + 37.5 + 37.5$

= 735

The surface area of the prism is 735 cm^2 .

Since the bases of a triangular prism are congruent, we can say:

Surface area = sum of the areas of the 3 rectangular faces

+ $2 \times$ area of one triangular base

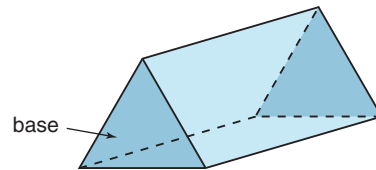

Example 1

Find the surface area of this prism.

Each dimension is given to the nearest centimetre.

A Solution

Draw a net. Label its dimensions.

The prism is 40 cm tall, so each rectangle has height 40 cm.

The width of each rectangle is a side length of the triangular base.

One rectangle has area: $40 \times 20 = 800$

Another rectangle has area: $40 \times 31 = 1240$

The third rectangle has area: $40 \times 29 = 1160$

The triangular base has area: $\frac{1}{2} \times 31 \times 18 = 279$

The surface area = $800 + 1240 + 1160 + 2 \times 279$
 $= 3758$

The surface area of the prism is 3758 cm^2 .

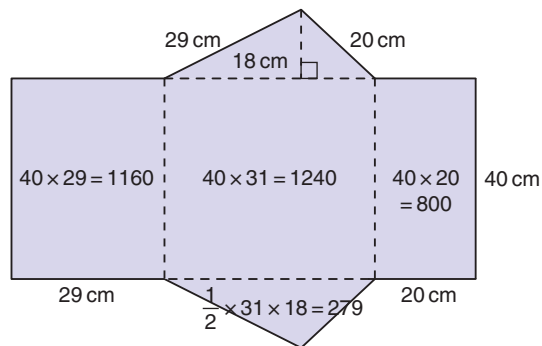
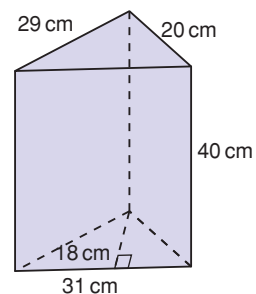

Instead of drawing a net, we can visualize each face as we calculate its area.

Example 2

A wooden doorstep is a triangular prism. It is to be painted. The bottom rectangular face is covered with rubber and will not be painted.

Find the total surface area to be painted.

Each dimension is given to one decimal place.

A Solution

There are 4 faces to be painted: 2 triangular bases, the slanted rectangular face, and the vertical rectangular face

The area of each triangular base is: $\frac{1}{2} \times 15.9 \times 5.0 = 39.75$

The slanted rectangular face has area: $8.9 \times 16.7 = 148.63$

The vertical rectangular face has area: $5.0 \times 8.9 = 44.5$

Total area to be painted is: $(2 \times 39.75) + 148.63 + 44.5 = 272.63$

The surface area to be painted is 272.6 cm^2 to one decimal place.

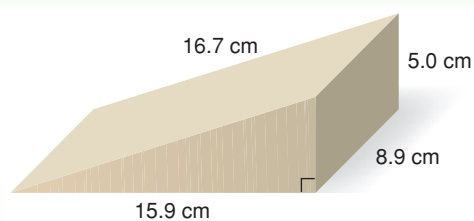

Discuss the ideas

1. Explain how the net of a triangular prism can help you find the surface area of the prism.
2. What do you know about the rectangular faces in an equilateral triangular prism?
How would you find the surface area of the prism?
3. What do you know about the rectangular faces in an isosceles triangular prism?
How would you find the surface area of the prism?

Practice

Check

Use a calculator when you need to.

4. Here is the net of a right triangular prism. The area of each face is given. What is the surface area of the prism?
How did you find out?

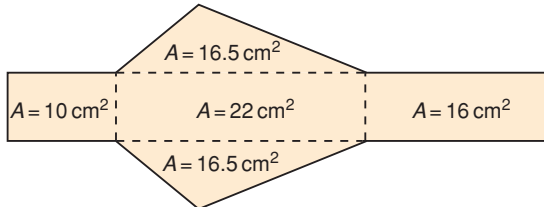

5. Here is a right isosceles triangular prism. Which faces are congruent and share the same area? How do you know?

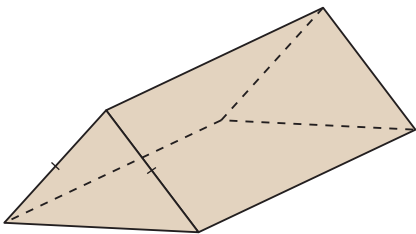

6. Sketch a net of this triangular prism. What is its surface area?

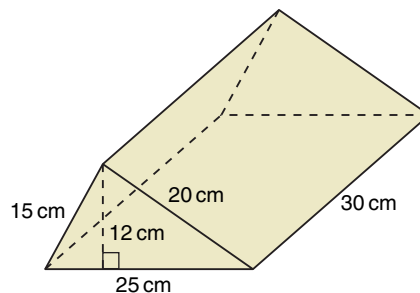

7. a) Calculate the area of each net.

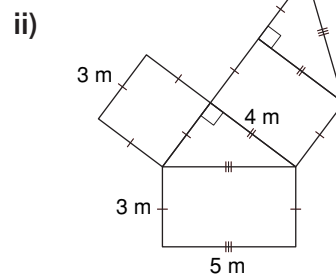
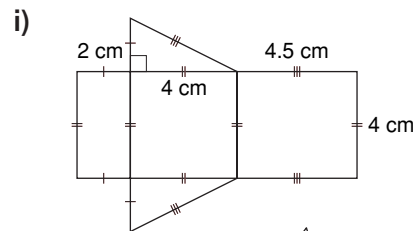

- b) How does the area of each net compare to the surface area of the prism formed by the net?

Apply

8. Calculate the surface area of each prism. Order the prisms from greatest to least surface area. Show your work.

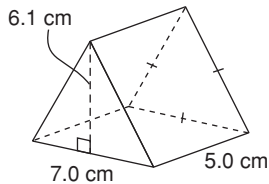

Prism A

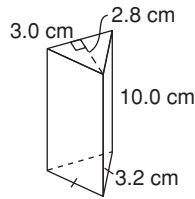

Prism B

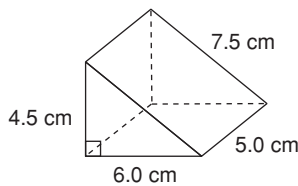

Prism C

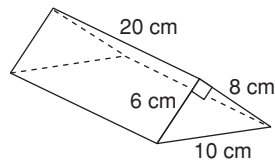

Prism D

9. Find the surface area of each triangular prism.

a)

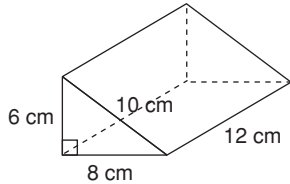

b)

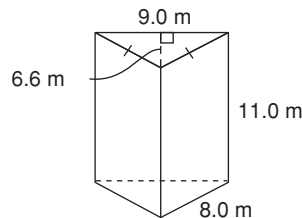

c)

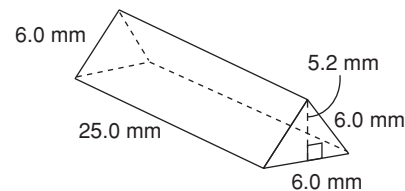

10. The 3 rectangular faces of a triangular prism have areas 30 cm^2 , 40 cm^2 , and 50 cm^2 . The 2 triangular bases have a combined area of 12 cm^2 . What are the dimensions of the triangular prism? Explain your thinking using diagrams, numbers, and words.

11. Suppose you want to construct a right triangular prism 15 cm long with the greatest surface area. Which of these triangles should you choose for its base? Explain your choice.

a)

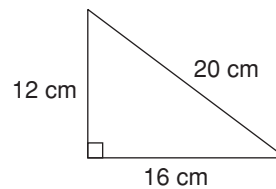

b)

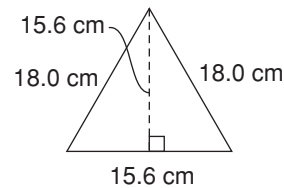

c)

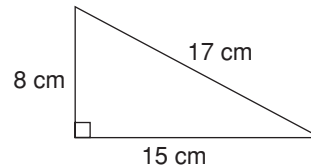

12. **Assessment Focus** A student said, "If you double all the dimensions of a triangular prism, you will double its surface area." Is the student correct? Use words, numbers, and diagrams to explain your answer.

- 13.** How much metal is needed to build this water trough?

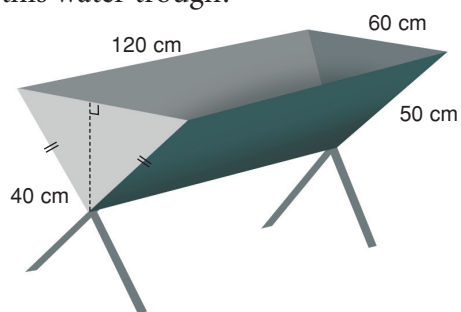

- 14.** Daniel wants to cover the outside of an empty 3-ring binder with plastic. Each dimension of the binder has been written to one decimal place. How much plastic is needed to cover the outside of the binder? What assumptions do you make?

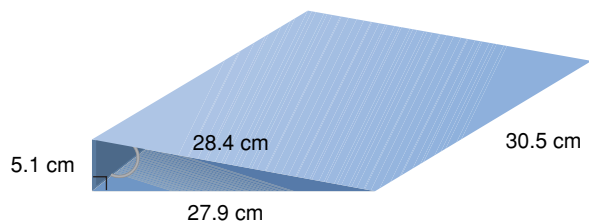

- 15.** A rectangular prism is cut as shown to form two congruent triangular prisms. Is the surface area of one triangular prism one-half the surface area of the rectangular prism? Justify your answer.

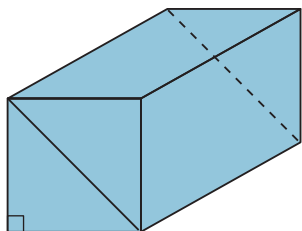

- 16. Take It Further** This triangle is one base of a right triangular prism. What should the length of the prism be so its surface area is between 100 cm^2 and 150 cm^2 ? Show your work.

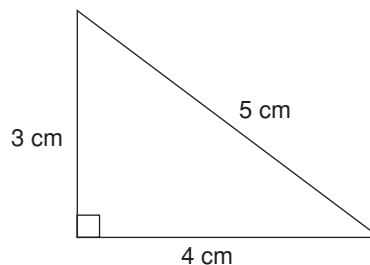

- 17. Take It Further**
- Use the Pythagorean Theorem. Find the height of a triangular base of this prism.
 - What is the surface area of the prism? Give your answer to the nearest square centimetre.

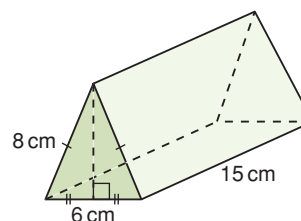

Reflect

How is the strategy for finding the surface area of a triangular prism similar to the strategy for finding the surface area of a rectangular prism? How is it different?

Mid-Unit Review

LESSON

4.1

1. Sketch two different nets for each object.

a)

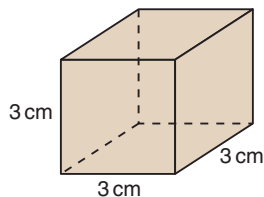

b)

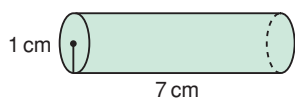

4.2

2. a) Which diagrams are nets?
How do you know?
b) For each net, identify the object it forms.

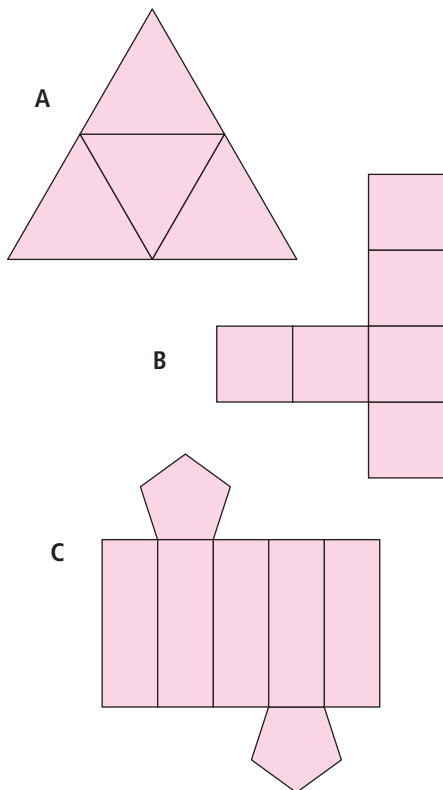

4.3

4.4

3. Find the surface area of each prism.

a)

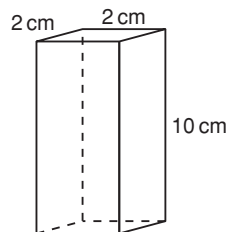

b)

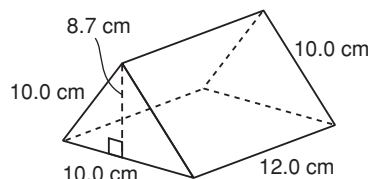

4. A skyscraper is shaped like a rectangular prism. The outside of the building is almost entirely glass. The base of the building is 58 m by 75 m. The height of the skyscraper is 223 m. What is the area of glass needed to cover the building?
5. A clerk gift wrapped some golf clubs in a box shaped like a right triangular prism. The base of the prism is an equilateral triangle with side length 28 cm and height about 24 cm. The prism is 120 cm long.
- a) What is the surface area of the box?
- b) How much wrapping paper does the clerk need? What assumptions do you make?

4.5

Volume of a Right Rectangular Prism

Focus Develop and use a formula to calculate the volume of a right rectangular prism.

This rectangular prism is made from 1-cm cubes. What is the volume of the prism?

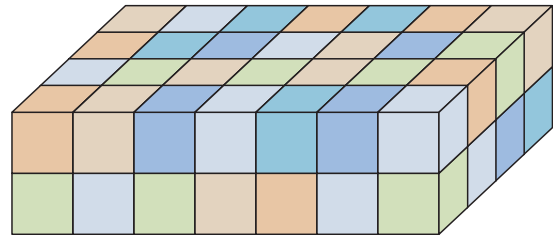

Investigate

Work with a partner.

You will need 2 empty cereal boxes, a ruler, and a calculator.

- Compare the two boxes.
Which box do you think holds more cereal?
Why do you think so?
- Find the volume of each box.
Which box has the greater volume?
How does this compare with your prediction?
- Work together to write a formula you can use to find the volume of any rectangular prism.
- Suppose you know the area of one face of a cereal box. What else do you need to know to find the volume of the box?
- Work together to write a formula for the volume of a right rectangular prism in terms of the area of its base.



Reflect & Share

Compare your formula with that of another pair of classmates.

Did you write the same formula?

If not, do both formulas work? Explain.

Compare the formulas for the volume of a right rectangular prism and the area of a rectangle. What do you notice?

How can you explain this?

Connect

This box is a right rectangular prism.

The volume of the box is the number of centimetre cubes the box holds.

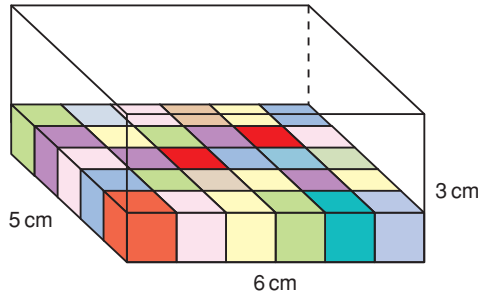

Recall that, when the dimensions are measured in centimetres (cm), the volume is measured in cubic centimetres (cm³).

One layer of cubes will be 5 cm wide and 6 cm long.

So, 5×6 , or 30 cubes fit in one layer.

The box is 3 cm high, so 3 layers can fit.

The total number of cubes is $30 \times 3 = 90$.

So, the volume of the box is 90 cm³.

One way to write the volume of the box:

Volume = the number of cubes in one layer \times the number of layers

This is the same as:

Volume = the area of the base of the box \times its height

This is true for all rectangular prisms.

We can use variables to write a formula for the volume of a rectangular prism.

Let A represent the base area and h represent the height.

Then, the volume of a rectangular prism is:

$$V = A \times h \text{ or } V = Ah$$

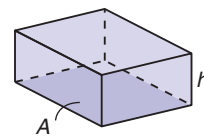

Example 1

The area of the base of a fish tank is 2013 cm².

The height of the tank is 30 cm.

Find the volume of the fish tank.

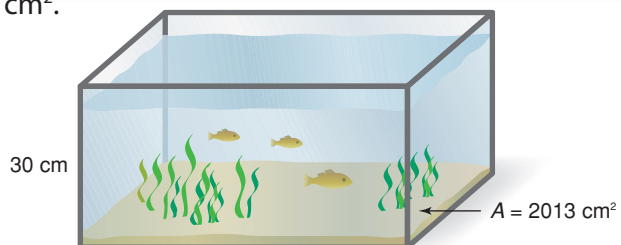

▶ A Solution

The fish tank is a right rectangular prism with base area 2013 cm^2 and height 30 cm .

$$\begin{aligned}\text{Volume} &= \text{base area} \times \text{height} \\ &= 2013 \times 30 \\ &= 60\,390\end{aligned}$$

The volume of the fish tank is $60\,390 \text{ cm}^3$.

Example 2

A deck of 54 cards fits in a box shaped like a right rectangular prism.

The box has dimensions 6.5 cm by 9.0 cm by 1.6 cm .

What is the volume of the box?

Give the answer to the nearest cubic centimetre.

▶ A Solution

Draw a diagram.

Label each dimension.

Let the base be one rectangle with length 9.0 cm and width 6.5 cm .

$$\begin{aligned}A &= 9.0 \times 6.5 \\ &= 58.5\end{aligned}$$

The area of the base is 58.5 cm^2 .

The height of the box is 1.6 cm .

Use the formula: $V = Ah$

$$\begin{aligned}V &= 58.5 \times 1.6 && \text{Use a calculator.} \\ &= 93.6\end{aligned}$$

The volume is 94 cm^3 , to the nearest cubic centimetre.

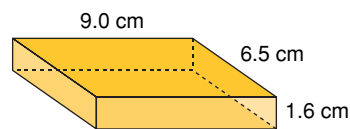

Discuss the ideas

1. Suppose the rectangular prism in *Connect* holds 210 centimetre cubes. How high is the box? Assume the area of the base is unchanged.
2. When you find the volume of a right rectangular prism, does it matter which face you use as the base?
3. For *Example 2*, suggest a different way to find the volume of the box.

Practice

Use a calculator when it helps.

Check

4. The base area and height of each prism are given. Find the volume of each prism.

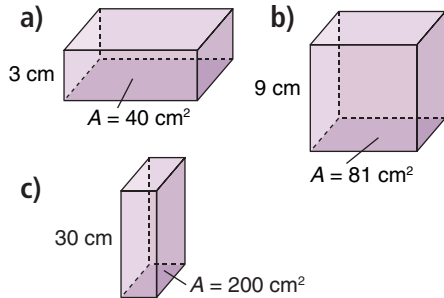

5. A box of laundry detergent has dimensions 28 cm by 16 cm by 25 cm.

- a) Sketch the box.
Label each dimension.
- b) What volume of detergent will fill the box?

6. a) Find the volume of each prism.

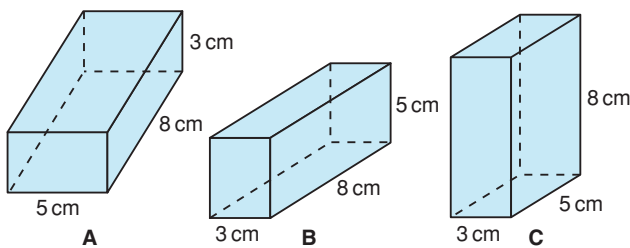

- b) What do you notice about the volumes in part a?
- c) Does the volume of a rectangular prism change when you place the prism on a different base? Justify your answer.

Apply

7. Find the volume of each rectangular prism.

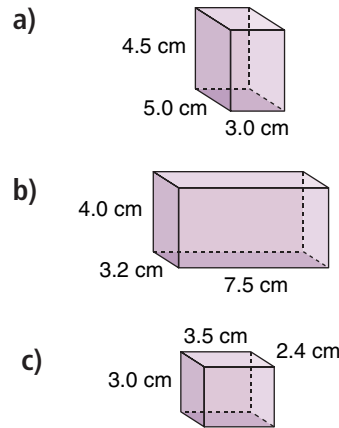

8. Find a right rectangular prism in the classroom. Measure its dimensions. Find its volume.
9. Each dogsled team that enters the Iditarod has a portable doghouse for each sled dog. Two mushers are comparing the sizes of their doghouses. Each of Rick's doghouses is 94 cm by 63 cm by 71 cm. Each of Susan's doghouses is 109 cm by 71 cm by 81 cm.
- a) What is the volume of each doghouse?
- b) About how many times as great as the volume of Rick's doghouse is the volume of Susan's doghouse?

- 10.** Suppose a milk carton is 10 cm wide and 10 cm long. How tall must the carton be to hold 1 L of milk?

Recall $1 \text{ cm}^3 = 1 \text{ mL}$.

- 11.** Large trucks often tow trailers that are shaped like right rectangular prisms. A standard trailer is 2.74 m by 2.43 m by 6.1 m.
- What is the greatest volume of cargo a standard trailer can hold?
 - How many trailers would it take to transport 100 m^3 of goods? What assumptions do you make?



- 12.** A rectangular swimming pool is to be filled with water. The pool has a uniform depth of 2 m and is surrounded by a wooden deck. The pool is 20 m wide and 50 m long. How much water is needed in each case?
- The pool is filled to the level of the deck.
 - The pool is filled to within 20 cm of the level of the deck.
 - The pool is half filled.

13. Assessment Focus

- Sketch all possible right rectangular prisms with volume 36 cm^3 . Label each prism with its dimensions in centimetres. How do you know you have found all possible prisms?
 - Use the prisms you sketched.
 - Which prism has the greatest surface area?
 - Which prism has the least surface area? How did you find out?
- 14.** Philip made fudge that filled a 20-cm by 21-cm by 3-cm pan.
- What is the volume of the fudge?
 - Philip shares the fudge with his classmates. There are 30 people in the class. How much fudge will each person get?
 - How could Philip cut the fudge so each person gets an equal sized piece? Sketch the cuts Philip could make.
 - What are the dimensions of each piece of fudge in part c?



- 15.** Sketch a right rectangular prism. Label its dimensions. What do you think happens to the volume of the prism when:
- its length is doubled?
 - its length and width are doubled?
 - its length, width, and height are doubled?

Investigate to find out.

Show your work.

Will the results be true for all rectangular prisms?

Why do you think so?

16. Take It Further

How can you double the volume of a right rectangular prism?

Does its surface area double, too?

Explain.

17. Take It Further

Students in a Grade 8 class are filling shoeboxes with toys for children in other countries. A shoebox measures 30 cm by 18 cm by 16 cm.

- Find the volume of a shoebox.

- The students fill 24 shoeboxes. Eight shoeboxes are packed into a larger box. What could the dimensions of this larger box be?
- What are the most likely dimensions of the larger box? Justify your choice.

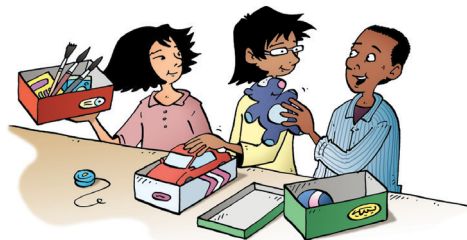

18. Take It Further

- Sketch 3 different right rectangular prisms with volume 24 cm^3 .
- Which prism has the greatest surface area? Which prism has the least surface area?
- Sketch a prism with a greater surface area but the same volume. Describe the shape of this prism.
- Sketch a prism with a lesser surface area but the same volume. Describe the shape of this prism.

Reflect

Suppose you know the area of one face of a rectangular prism.

What else do you need to know to find the volume of the prism? Explain.

Suppose you know the volume of a rectangular prism.

Can you find its dimensions? Use words and diagrams to explain.

Largest Box Problem



HOW TO PLAY

1. Cut congruent squares from the four corners of the grid. Think about what size the squares should be to make a box with the greatest volume.

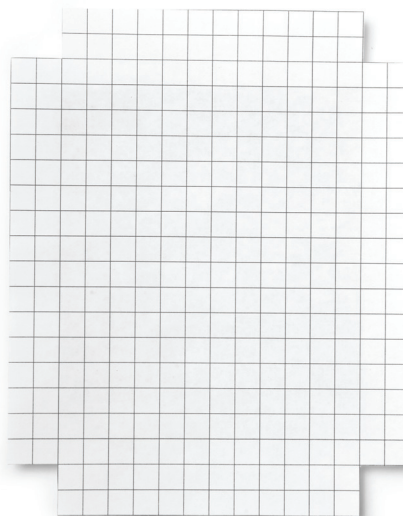

YOU WILL NEED

20-cm by 16-cm grids;
scissors; tape; rulers

NUMBER OF PLAYERS

4

GOAL OF THE GAME

To make a box with the
greatest volume

2. Fold, then tape the sides to form an open box.
3. Measure the length, width, and height of your box. Find its volume.
4. Compare the volume of your box to the volumes of the boxes the other players in your group made. The player whose box has the greatest volume wins.

Reflect

- What strategies did you use to make the box with the greatest volume?
- Compare results with another group of students. How do you know you cannot make a box with a greater volume?

4.6

Volume of a Right Triangular Prism

Focus

Develop and use a formula to find the volume of a right triangular prism.

Here is another way to visualize a triangular prism. A triangle is translated in the air so that each side of the triangle is always parallel to its original position.



How could you use this model to find the volume of the prism?

Investigate

Work with a partner.

You will need scissors and tape.

Your teacher will give you a large copy of these nets.

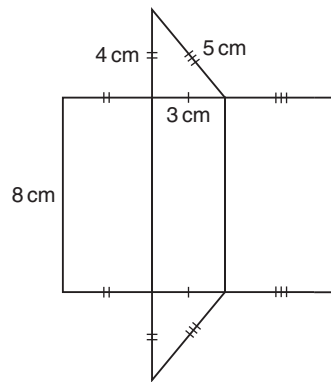
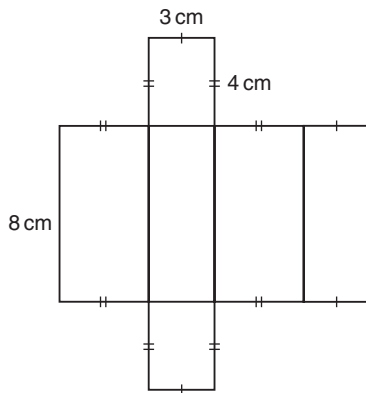

- Identify the prism each net will form.
- Cut out the nets and construct the right prisms.
- Visually compare the volumes of the two prisms.
How are they related?
- What is the volume of the rectangular prism?
How can you use this volume to find the volume of the triangular prism?
- What is a formula for the volume of a rectangular prism?
How can you use this formula to write a formula for the volume of a triangular prism?

Reflect & Share

Combine your prisms with those of another pair of classmates. How can you arrange the prisms to verify the relationship you found in *Investigate*?

Connect

The volume of a right rectangular prism can be written as:

$$V = \text{base area} \times \text{length}$$

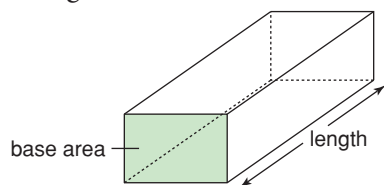

To avoid confusion between the height of a triangle and the height of the prism, use *length* to describe the height of the prism.

Suppose we draw a triangle on the base of the prism so that the base of the triangle is one edge, and the third vertex of the triangle is on the opposite edge.

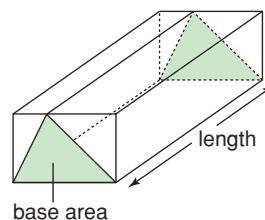

The volume of a triangular prism with this base, and with length equal to the length of the rectangular prism, is one-half the volume of the rectangular prism.

The volume of a right triangular prism

is also: $V = \text{base area} \times \text{length}$

The base is a triangle, so the base area is the area of the triangle.

We can use variables to write a formula for the volume of a triangular prism.

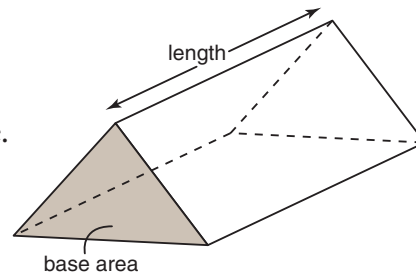

For the triangular prism below:

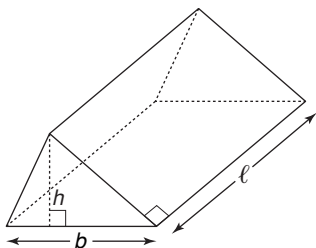

The length of the prism is ℓ .

Each triangular face has base b and height h .

The volume of the prism is:

$$V = \text{base area} \times \text{length}, \text{ or } A \times \ell, \text{ or } A\ell, \text{ where } A = \frac{1}{2}bh$$

Example 1

Find the volume of the prism.

A Solution

The area of the base of a triangular prism is 12 cm^2 .

The length of the prism is 9 cm .

Volume of triangular prism = base area \times length

$$\begin{aligned}V &= 12 \times 9 \\ &= 108\end{aligned}$$

The volume of the triangular prism is 108 cm^3 .

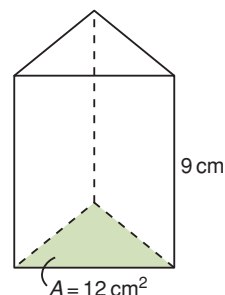

Example 2

Here is a diagram of Renee's new house.

What is the volume of the attic?

A Solution

The attic is a triangular prism.

Sketch the prism.

Use a variable to represent each dimension.

The base of the triangle is: $b = 8$

The height of the triangle is: $h = 3$

The length of the prism is: $\ell = 10$

Use: $V = A\ell$

First find A .

$$A = \frac{1}{2}bh$$

Substitute: $b = 8$ and $h = 3$

$$\begin{aligned}A &= \frac{1}{2} \times 8 \times 3 \\ &= 12\end{aligned}$$

Now find V .

Substitute: $A = 12$ and $\ell = 10$ into $V = A\ell$

$$\begin{aligned}V &= 12 \times 10 \\ &= 120\end{aligned}$$

The volume of the attic is 120 m^3 .

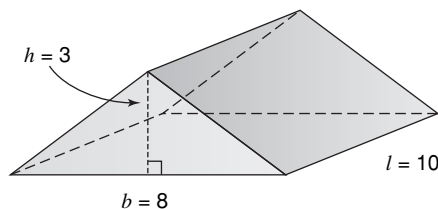
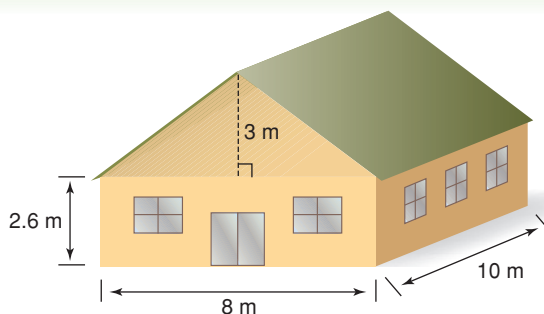

Discuss the ideas

1. A rectangular prism is cut in half to make 2 congruent triangular prisms.
What do you know about the volume of each triangular prism?
2. Any face can be used as the base of a rectangular prism.
Can any face be used as the base of a triangular prism? Explain.

Practice

Check

3. Each rectangular prism is divided into 2 congruent triangular prisms along the diagonal shown. The volume of each rectangular prism is given. Find the volume of each triangular prism.

a)

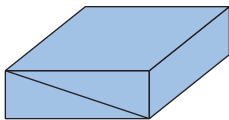

$$\text{Volume} = 450 \text{ cm}^3$$

b)

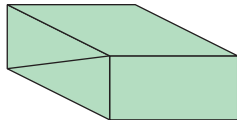

$$\text{Volume} = 624 \text{ cm}^3$$

4. The base area and length of each triangular prism are given. Find the volume of each prism.

a)

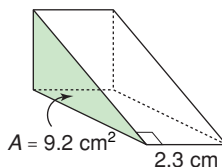

$$A = 9.2 \text{ cm}^2 \quad 2.3 \text{ cm}$$

b)

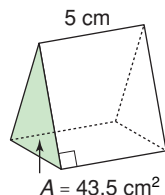

$$A = 43.5 \text{ cm}^2 \quad 5 \text{ cm}$$

c)

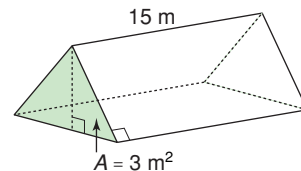

$$15 \text{ m} \quad A = 3 \text{ m}^2$$

5. Find the volume of each triangular prism.

a)

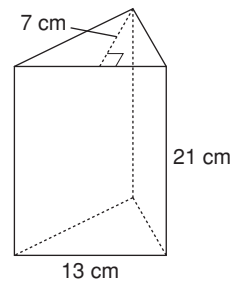

$$7 \text{ cm} \quad 13 \text{ cm} \quad 21 \text{ cm}$$

b)

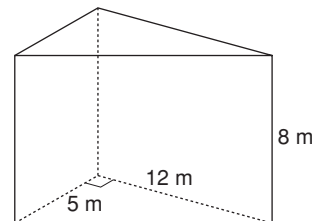

$$5 \text{ m} \quad 12 \text{ m} \quad 8 \text{ m}$$

c)

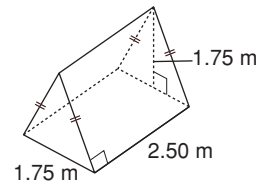

$$1.75 \text{ m} \quad 1.75 \text{ m} \quad 2.50 \text{ m}$$

Apply

6. Find the volume of each prism.

a)

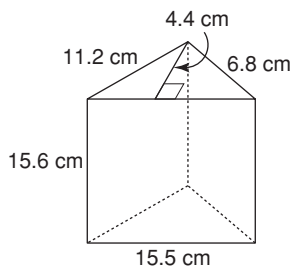

b)

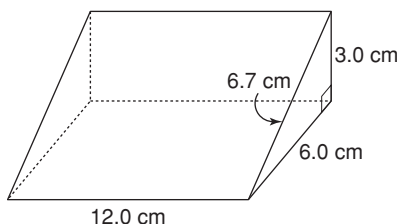

7. What is the volume of glass in this glass prism?

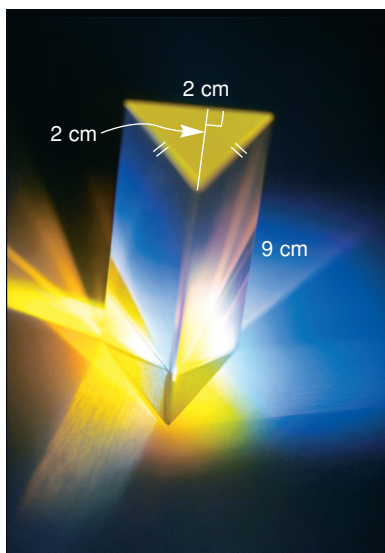

8. The volume of a right triangular prism is 30 cm^3 . Each triangular face has area 4 cm^2 .
How long is the prism?

9. Assessment Focus

a) Find possible values for A and ℓ for each volume of a right triangular prism. Sketch one possible triangular prism for each volume.

i) 5 cm^3

ii) 9 m^3

iii) 8 m^3

iv) 18 cm^3

b) How many different prisms can you find in each case?

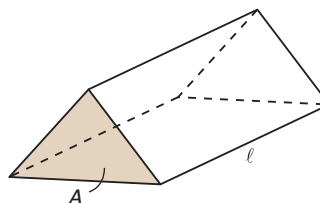

10. Chico has a wedge of cheddar cheese. He plans to serve the cheese as an appetizer before dinner.

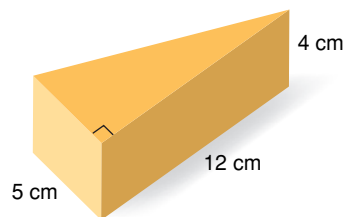

a) What volume of cheese does Chico have?

b) Suppose each person eats 20 cm^3 of cheese.
How many people will the cheese serve?

11. The volume of a triangular prism is 50 m^3 . The length of the prism is 5 m.
What is the area of each triangular face?

- 12.** Jackie uses this form to build a concrete pad.

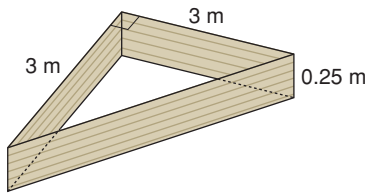

- a) How much concrete will Jackie need to mix to fill the form?
 b) Suppose Jackie increases the lengths of the equal sides of the form from 3 m to 6 m.
 How much more concrete will Jackie need to mix?
 Include a diagram.



- 13. a)** Predict which triangular prism has the greater volume.

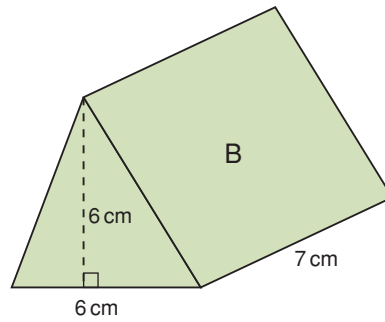
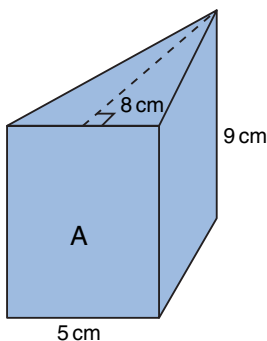

- b) Find the volume of each prism.
 Was your prediction correct?
 c) How could you change one dimension of Prism B so the two prisms have the same volume?
- 14. a)** Find the volume of this prism.

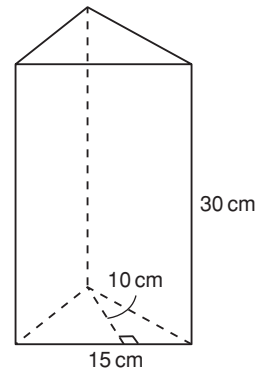

- b) Suppose the prism contains 1350 mL of water.
 What is the depth of the water?
 c) What percent of the volume of the prism is water?
- 15.** The volume of a right triangular prism is 198 cm^3 . Each triangular face is a right triangle with area 18 cm^2 . Find as many dimensions of the prism as you can.

16. Take It Further

A chocolate company produces different sizes of chocolate bars that are packaged in equilateral triangular prisms.

Here is the 100-g chocolate bar.



- Calculate the surface area and volume of the box.
- The company produces a 400-g chocolate bar. It has the same shape as the 100-g bar.
 - What are the possible dimensions for the 400-g box? How many different sets of dimensions can you find?
 - How are the dimensions of the two boxes related, in each case?

17. Take It Further

- Find the surface area and volume of this triangular prism.

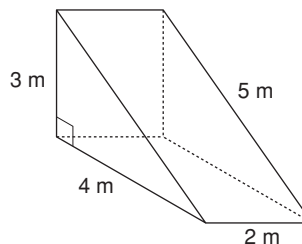

- What do you think happens to the surface area and volume when the length of the prism is doubled? Justify your prediction.
- What do you think happens to the surface area and volume when the base and height of the triangular face are doubled? Justify your prediction.
- What do you think happens to the surface area and volume when all the dimensions are doubled? Justify your prediction.
- For parts b to d, find the surface area and volume to verify your predictions.

Reflect

How did you use what you know about the volume of a right rectangular prism in this lesson?

4.7

Surface Area of a Right Cylinder

Focus Find the surface area of a right cylinder.

What is the area of this circle?

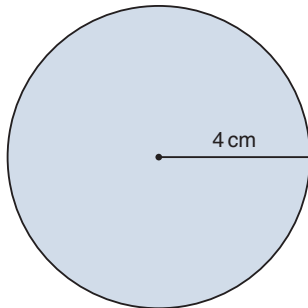

What is the circumference of this circle?

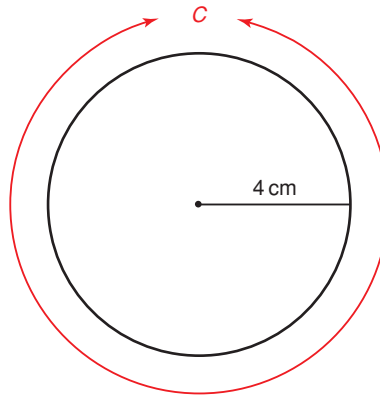

Investigate

Work with a partner.

You will need a cardboard tube, scissors, and tape.
Cut out two circles to fit the ends of the tube.
Hold a circle at each end of the tube.
You now have a right cylinder.

Find a way to calculate the surface area of the cylinder.



Reflect & Share

Share your strategy for finding the surface area with another pair of classmates.
Did you use the same strategy?
If not, do both strategies work?
How could you check?

Connect

The bases of a right cylinder are 2 congruent circles.
 The curved surface of a cylinder is a rectangle when laid flat.
 These 3 shapes make the net of a cylinder.

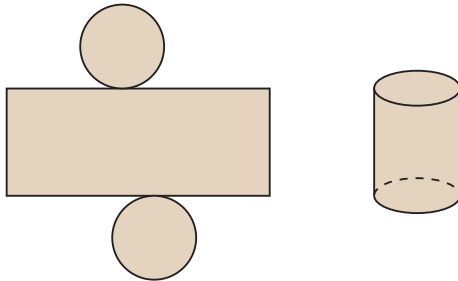

The surface area of a cylinder = $2 \times$ area of one circular base + area of a rectangle
 Label the cylinder and its net.

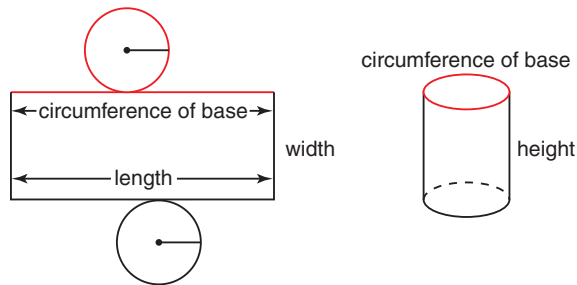

The width of the rectangle is equal to the height of the cylinder.
 The length of the rectangle is equal to the circumference of the base of the cylinder.

So, the area of the rectangle = circumference of base \times height of cylinder

When a cylinder is like a cardboard tube and has no circular bases, its surface area is the curved surface only:

Curved surface area = circumference of base \times height of cylinder

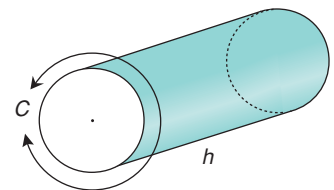

Example 1

Find the surface area of this cylinder.



▶ A Solution

Sketch the net.

Surface area = $2 \times$ area of one circle + area of the rectangle

- The area of the circle is: $A = \pi r^2$

Substitute: $r = 8$

$$\begin{aligned}\text{So, area of circle is: } A &= \pi \times 8^2 \\ &\doteq 201.06\end{aligned}$$

- The area of the rectangle = circumference \times height
 $= 2\pi r \times h$

Substitute: $r = 8$ and $h = 11$

Use a calculator. For π , press the π key.

$$\begin{aligned}\text{The area of the rectangle} &= 2\pi \times 8 \times 11 \\ &\doteq 552.92\end{aligned}$$

$$\begin{aligned}\text{Surface area} &\doteq 2 \times 201.06 + 552.92 \\ &= 955.04\end{aligned}$$

The surface area of the cylinder is about 955 cm^2 .

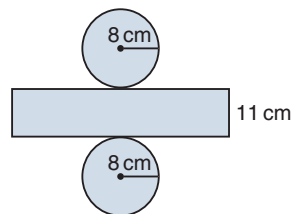

Example 2

A manufacturer produces a can with height 7 cm and diameter 5 cm.

What is the surface area of the label, to one decimal place?

▶ A Solution

Sketch the can.

The label does not cover the circular bases.

So, the surface area of the label is equal to the curved surface area of the can.

$$\begin{aligned}\text{Curved surface area} &= \text{circumference of base} \times \text{height of cylinder} \\ &= \pi d \times h\end{aligned}$$

Substitute: $d = 5$ and $h = 7$

Use a calculator. For π , press the π key.

$$\begin{aligned}\text{Curved surface area} &= \pi \times 5 \times 7 \\ &\doteq 109.956\end{aligned}$$

The surface area of the label is 110.0 cm^2 , to one decimal place.

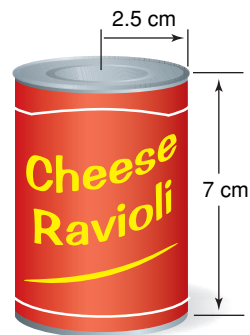

Discuss the ideas

- In *Example 2*, what is the surface area of the can?
The can is opened and one end removed.
What is the surface area of the open can?
- What is an algebraic formula for the surface area of a right cylinder with height h and radius r ?
- Why is the surface area of a cylinder always approximate?

Practice

Check

Give each area to the nearest square unit.

4. Find the area of each net.

a)

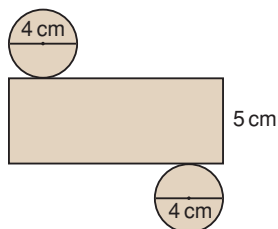

b)

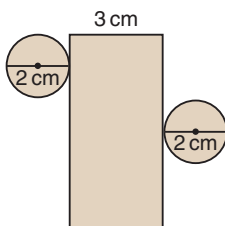

c)

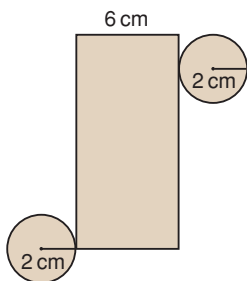

5. Describe the cylinder that each net in question 4 forms.

6. Calculate the curved surface area of each tube.

a)

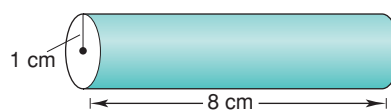

b)

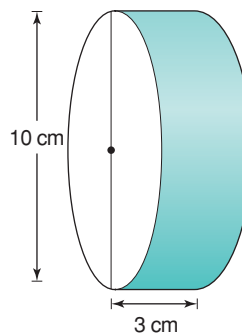

c)



7. Find a right cylinder in the classroom. Use thin string to find its circumference. Use a ruler to measure its radius and height. Calculate the surface area of the cylinder.

Apply

8. Calculate the surface area of each cylinder.

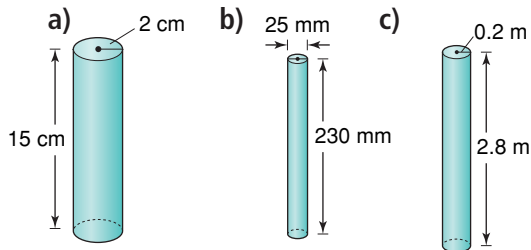

9. A cylindrical tank has diameter 3.8 m and length 12.7 m. What is the surface area of the tank?
10. Cylindrical paper dryers are used in pulp and paper mills. One dryer has diameter 1.5 m and length 2.5 m. What is the area of the curved surface of this dryer?
11. A wooden toy kit has different painted solids. One solid is a cylinder with diameter 2 cm and height 14 cm.



- a) What is the surface area of the cylinder?
- b) One can of paint covers 40 m^2 . Each cylinder is painted with one coat of paint. How many cylinders can be painted with one can of paint?

12. Assessment Focus

A soup can has diameter 6.6 cm. The label on the can is 8.8 cm high. There is a 1-cm overlap on the label. What is the area of the label?

13. A hot water tank is cylindrical. Its interior is insulated to reduce heat loss. The interior has height 1.5 m and diameter 65 cm. What is the surface area of the interior of the tank? Give the answer in two different square units.
14. A tom-tom hoop drum is made of stretched membranes, called heads, which are held tightly across a tubular shell. The drum has diameter 30 cm and height 30 cm. The shell of the drum is made of 5 layers of birch sheathing.

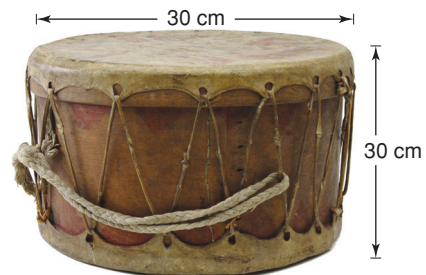

- a) How much sheathing is needed to make the shell?
- b) Suppose the drum has two heads. How much membrane would you need to make the heads? What assumptions do you make?

15. A candy company can sell fruit gums in rectangular boxes or in cylindrical tubes. Each box is 8 cm by 3 cm by 7 cm. Each cylinder has radius 3 cm and height 6 cm. The company wants the packaging that uses less material. Which packaging should the company choose? Justify your choice.

16. Take It Further

The curved surface area of a solid cylinder is 660 cm^2 .

The cylinder has height 10 cm.

- What is the circumference of the cylinder?
- What is the radius of the cylinder?
- What is the area of one circular base?
- What is the surface area of the cylinder?

17. Take It Further Benny places a glass cylinder, open at one end, over a rose cutting in his garden. The cylinder has diameter 9 cm and height 20 cm. To make sure animals cannot knock the cylinder over, Benny covers the bottom 5 cm of the cylinder with soil. What is the surface area of the cylinder exposed to the sun?



Math Link

History

In the late 1800s, Thomas Edison developed the earliest method for recording sound, the phonograph cylinder. The open cylinder was made of wax. Audio recordings were etched on its outside surface. The sounds were reproduced when the cylinder was played on a mechanical phonograph. There are about 3312 original wax cylinders recorded by First Nations and French Canadian people on display at the Canadian Museum of Civilization in Gatineau, Quebec.



The standard wax cylinder had diameter about 5.5 cm and height 10.5 cm. What surface area was available to be etched?

Reflect

How is the formula for the surface area of a cylinder related to the net of the cylinder? Include a diagram in your explanation.

4.8

Volume of a Right Cylinder

Focus

Develop and use a formula to find the volume of a right cylinder.

Here is a way to visualize a right cylinder. A circle is translated through the air so that the circle is always parallel to its original position.

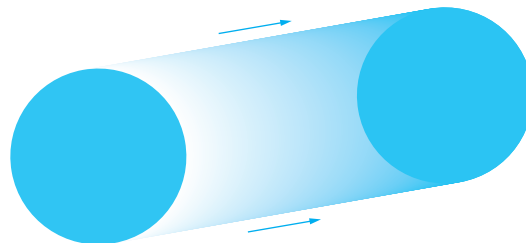

How does this relate to the triangular prism in Lesson 4.6, page 202?

Investigate

Work with a partner.

You will need 2 identical rectangular sheets of construction paper, rice, and tape.

- Roll one sheet of paper lengthwise to create a tube. Tape the edges together. Repeat with the second sheet of paper. This time roll the paper widthwise.
- Predict which tube has the greater volume. Use rice to check your prediction. Do the results match your prediction? Explain.
- Calculate the volume of the taller tube. How did you use the diameter and radius in your calculations? How did you use π ?



Reflect & Share

Share your strategy for calculating the volume with another pair of classmates.

Work together to write a formula for the volume of a right cylinder.

Use any of diameter, radius, height, and π in your formula.

Use your formula to find the volume of the shorter tube.

Connect

The volume of a right prism is: base area \times height

We can use this formula to find the volume of a right cylinder.

Example 1

The area of the base of a cylinder is about 154 cm^2 .

The height of the cylinder is 24 cm.

Find the volume of the cylinder.



A Solution

$$\begin{aligned}\text{Volume of a cylinder} &= \text{base area} \times \text{height} \\ &\doteq 154 \times 24 \\ &= 3696\end{aligned}$$

The volume of the cylinder is about 3696 cm^3 .

We can write an algebraic formula for the volume.

The base of a cylinder is a circle with radius r .

The area of a circle is: $A = \pi r^2$

Let the height of the cylinder be h .

$$\begin{aligned}\text{So, the volume of a cylinder is: } V &= \text{base area} \times \text{height} \\ &= \text{area of circle} \times \text{height} \\ &= \pi r^2 \times h \\ &= \pi r^2 h\end{aligned}$$

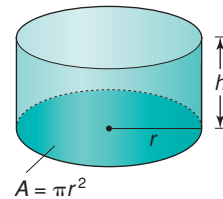

So, a formula for the volume of a cylinder is $V = \pi r^2 h$,
where r is the radius of its base, and h its height.

Example 2

In 2002, nine Pennsylvania miners were trapped in a flooded coal mine. Rescue workers drilled a hole about 90 cm wide and 73 m deep into the ground to make an escape shaft. The soil from the hole was removed and piled on the ground.

What volume of soil did the rescue workers remove? Give your answer to the nearest cubic metre.

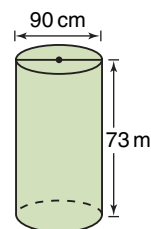

A Solution

The hole is shaped like a cylinder.
Draw a picture. Label the cylinder.

The radius of the base is: $\frac{90 \text{ cm}}{2} = 45 \text{ cm} = 0.45 \text{ m}$
The height of the cylinder is 73 m.

Use the formula for the volume of a cylinder:

$$V = \pi r^2 h$$

Substitute: $r = 0.45$ and $h = 73$

$$V = \pi(0.45)^2 \times 73 \quad \text{Use a calculator.}$$

$$\doteq 46.44$$

Both dimensions must have the same units.

The rescue workers removed 46 m³ of soil, to the nearest cubic metre.

Discuss the ideas

1. A student measured a can of beans. The height was 10.5 cm. The diameter was 7.4 cm. The student calculated the volume to be about 452 cm³. The label on the can shows the capacity as 398 mL. How is this possible?
2. Why was the base radius in *Example 2* converted from centimetres to metres? What would the volume be if the height was converted to centimetres?
3. In *Example 2*, why do you think the volume was asked for in cubic metres?

Practice

Check

Give each volume to the nearest cubic unit.

4. The base area and height of each cylinder are given to one decimal place. Calculate the volume of each cylinder.

a)

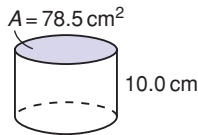

b)

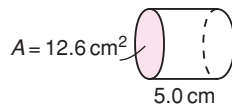

c)

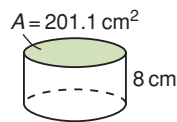

5. Calculate the volume of each cylinder.

a)

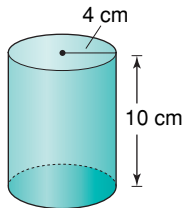

b)

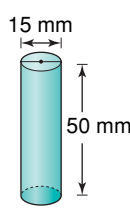

c)

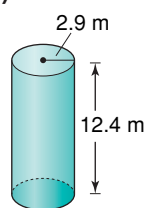

6. A candle mould is cylindrical. Its radius is 5 cm and its height is 20 cm . What volume of wax will fit in the mould?

Apply

7. Find a right cylinder in the classroom.
- Measure its height and diameter.
 - Calculate its base area.
 - Calculate its volume.

8. A hockey puck is a solid piece of rubber with the dimensions shown. How much rubber is used to make a hockey puck?

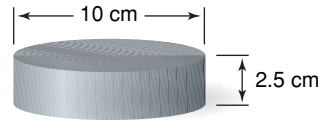

9. How do the volumes of these cylinders compare? How can you tell without calculating each volume?

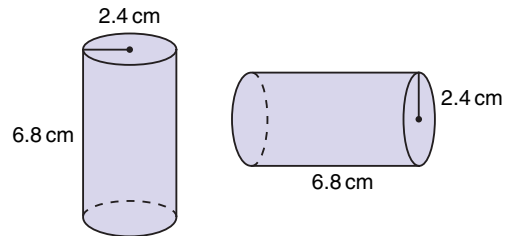

10. Kari has 125 mL of water. She wants to pour it into one of these cylindrical bottles. Which bottle will hold all the water? How do you know?
- Bottle A: $d = 7 \text{ cm}$, $h = 3 \text{ cm}$
 Bottle B: $r = 2 \text{ cm}$, $h = 6 \text{ cm}$
 Bottle C: $r = 3.5 \text{ cm}$, $h = 7 \text{ cm}$
 Bottle D: $d = 3 \text{ cm}$, $h = 4 \text{ cm}$

11. **Assessment Focus** Frozen apple juice comes in cylindrical cans. A can is 12 cm high with radius 3.5 cm .
- What is the capacity of the can?
 - What happens to the capacity of the can if the dimensions of the radius and height are switched? Why does this happen?

- 12.** A core sample of soil is cylindrical. The length of the core is 300 mm. Its diameter is 15 cm. Calculate the volume of soil.

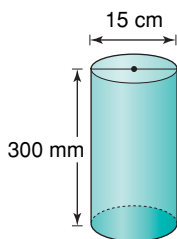

- 13.** Carol and Tom are drilling a well for water at their cottage in Lac La Hache, B.C. The drill is about 15 cm wide. Carol and Tom found water at a depth of 25 m. About how much soil did they remove before they found water?
- 14.** A farmer has 3 cylindrical containers to hold feed. Each container has radius 91 cm and height 122 cm. What is the total volume of the three containers? How did you find out?
- 15.** Orange juice concentrate is poured into cylindrical cans with diameter 7 cm and height 12 cm. A space of 1.5 cm is left at the top of the can to allow for expansion when the concentrate freezes. What volume of concentrate is poured into each can?

- 16. Take It Further** Which right cylinder do you think has the greater volume?
- a cylinder with radius 1 m and height 2 m, or
 - a cylinder with radius 2 m and height 1 m
- How can you find out without using a calculator? Explain.

- 17. Take It Further**
- A concrete column in a parkade is cylindrical. The column is 10 m high with diameter 3.5 m.
- What is the volume of concrete in one column?
 - There are 127 columns in the parkade. What is the total volume of concrete?
 - Suppose the concrete in part a is made into a cube. What would the dimensions of the cube be?

- 18. Take It Further** A study shows that consumers think the diameter of a large can of coffee is too wide. The study suggests that a narrower can would increase sales. The original can has diameter 20 cm and height 18 cm. Suppose the diameter of the can is decreased by 20% without changing the volume. What is the height of the new can?

Reflect

How did your knowledge of circles help you in this lesson?

Choosing the Correct Answer

Have you ever written a multiple-choice test?
Many students like multiple-choice tests because they know
the correct answer is one of the choices.



The other choices – called *distractors* – are created by making common mistakes.



Answer these multiple-choice questions.
Try to answer each question before you look at the choices.
What mistakes lead to the other choices?

1. A rectangular prism has dimensions 4 m by 6 m by 3 m.
What is the surface area of the prism?
a) 54 m^2 b) 72 m^2 c) 108 m^2 d) 144 m^2
2. What is the volume of this triangular prism?

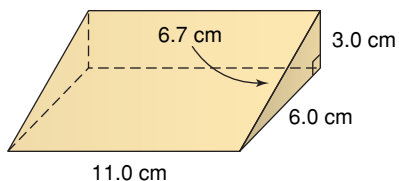

- a) 110.6 cm^3
- b) 99 cm^3
- c) 190.7 cm^3
- d) 198 cm^3

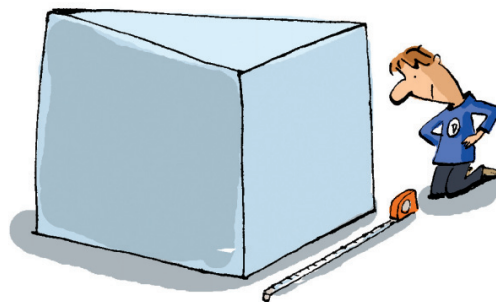

Here are some strategies you can use to help choose the correct answer for a multiple-choice question.

Before you start

- Make sure you understand what you are supposed to do.
 - Is it okay to guess?
 - Is there only one correct answer?
 - Where should you record your answer?
 - Are you supposed to show your work?

For each question

- Read the question carefully. Underline the key words.
- Draw a sketch or make a calculation if it helps.
- Try to answer the question before you look at the choices.
- Read all the choices.
- If your answer doesn't appear as a choice, read the question again. Look for any mistakes you might have made.
- If you still have trouble deciding, read each choice again.
 - Cross out any choices you know are not correct.
 - If two choices appear to be similar, identify any differences.



Organizing your time and checking

- Leave questions that you are unsure of until the end.
- If it is okay to guess, make your best guess. Do so after you have eliminated the choices you know are not correct.
- Read all the questions and your choices. Check that you have not missed any questions.

Unit Review

What Do I Need to Know?

✓ Right Rectangular Prism

Surface area = $2 \times$ area of Rectangle A
 $+ 2 \times$ area of Rectangle B
 $+ 2 \times$ area of Rectangle C

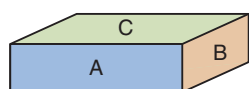

Volume = base area \times height

$$V = Ah,$$

where A represents the area of the base

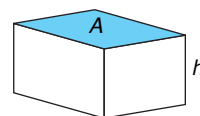

✓ Right Triangular Prism

The length of the prism is ℓ . Each triangular base has height h and base b .

Surface area = sum of the areas of 3 rectangular faces $+ 2 \times$ area of one triangular base

Volume = area of triangular base \times length of prism

$$V = A\ell \text{ where } A = \frac{1}{2}bh$$

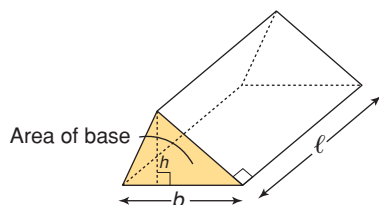

✓ Right Cylinder

The height of a cylinder is h and its radius r .

Surface area = $2 \times$ area of one circular base
 $+ \text{area of a rectangle}$

Curved surface area = circumference of base
 \times height of cylinder

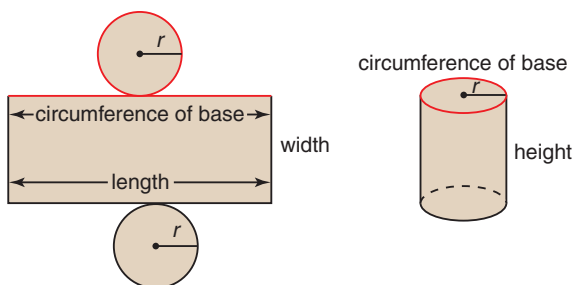

Volume = base area \times height

$$V = \pi r^2 h$$

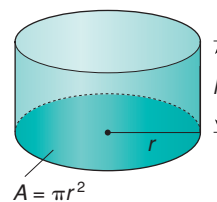

What Should I Be Able to Do?

LESSON

4.1

1. Draw three different nets for the same right rectangular prism.
What must be true for a net to be that of a rectangular prism?
2. For each net, identify the object it folds to form.

a)

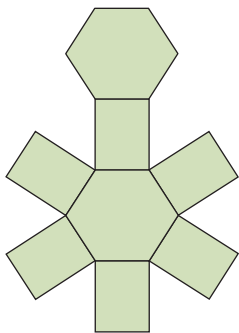

b)

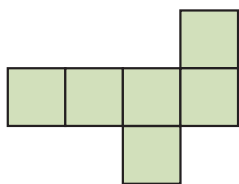

c)

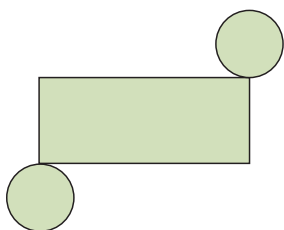

d)

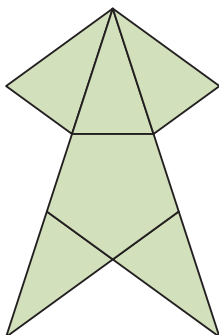

4.2

3. Predict which diagram is a net of a triangular prism. Your teacher will give you a large copy of each diagram. Cut out and fold them to confirm your prediction. How might the diagram that is not a net be fixed so it is a net?

a)

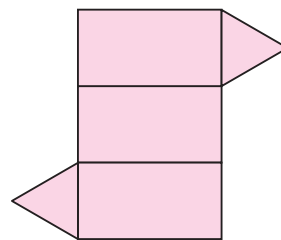

b)

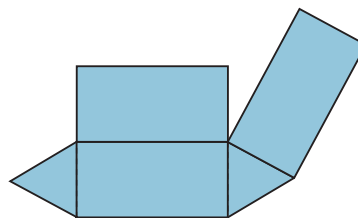

4. Which diagrams are nets?

For each net, identify the object.

For each diagram that is not a net, explain how to change it so it is a net.

a)

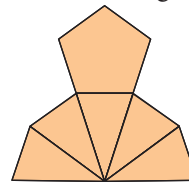

b)

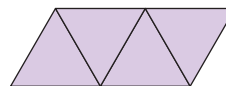

c)

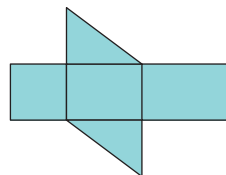

LESSON

4.3

5. A cube has edge length 4 cm.
 a) What is its surface area?
 b) What shortcut could you use to find the surface area?

4.3

4.5

6. Find the surface area and volume of each rectangular prism.

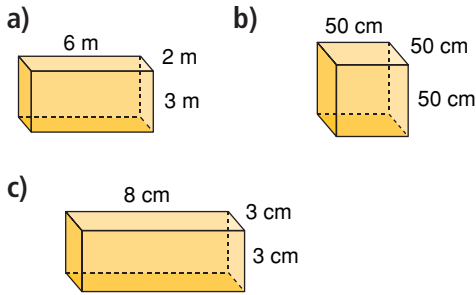

7. Elizabeth wallpapers 3 walls of her bedroom. She paints the 4th wall. This is one of the smaller walls. The room has length 4 m, width 6 m, and height 3 m. A roll of wallpaper covers about 5 m^2 . A 4-L can of paint covers about 40 m^2 .

- a) How much wallpaper and paint should Elizabeth buy?
 b) What assumptions do you make?

8. a) Sketch all possible right rectangular prisms with volume 28 m^3 . Each edge length is a whole number of metres. Label each prism with its dimensions.
 b) Calculate the surface area of each prism.

9. The base area, A , and height, h , of a right rectangular prism are given. Find the volume of each prism.

- a) $A = 6 \text{ m}^2$, $h = 4 \text{ m}$
 b) $A = 15 \text{ cm}^2$, $h = 3 \text{ cm}$

4.6

10. Here is a net of a triangular prism.

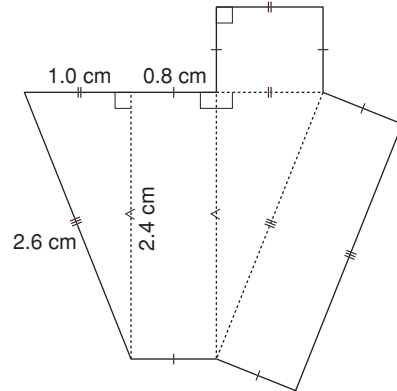

- a) Calculate the surface area of the prism in square centimetres.
 b) Calculate the volume of the prism in cubic centimetres.

11. a) Calculate the surface area of this prism. Sketch a net first, if it helps.

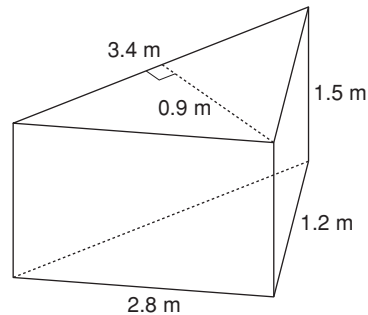

- b) Calculate the volume of the prism.
 c) Suppose you sit the prism on one of its rectangular faces. How does this affect the volume?

LESSON

- 12.** The horticultural society is building a triangular flower bed at the intersection of two streets.

The edges of the bed are raised 0.25 m. How much soil is needed to fill this flower bed?

Justify your answer.

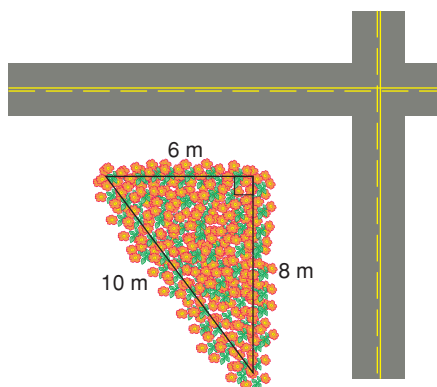

- 13.** Alijah volunteers with the horticultural society. He wants to increase the size but not the depth of the flower bed in question 12.

- a) How can Alijah change the dimensions so that:
- the flower bed remains triangular, and
 - the area of the ground covered by the bed doubles?
- b) Sketch the new flower bed. Label its dimensions.
- c) How does the change in size affect the volume of soil needed? Explain.

4.7

4.8

- 14.** The label on a can of soup indicates a capacity of 398 mL. The height of the can is 10.5 cm. The diameter of the can is 7.2 cm.

- a) Find the actual capacity of the can in millilitres.
- b) Give a reason why the answer in part a is different from the capacity on the label.

- 15.** A sculpture comprises 3 cylindrical columns. Each column has diameter 1.2 m. The heights of the columns are 3 m, 4 m, and 5 m. The surfaces of the cylinders are to be painted. Calculate the area to be painted. (The base each column sits on will *not* be painted.)

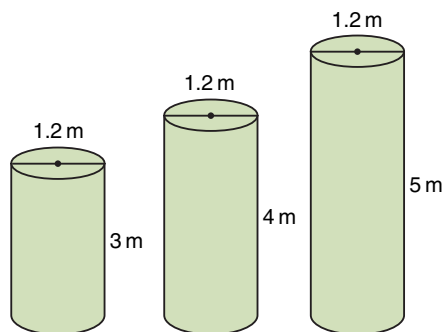

- 16.** A building is to be built in the shape of a cylinder. It will have height 155 m and diameter 25 m. The outside of the building will be made of zinc panels. What area of zinc panels is needed to cover the vertical surface of the building?

Practice Test

- Describe the object this net folds to form.
 - Fold a copy of the net to check your prediction.
 - Sketch the object.

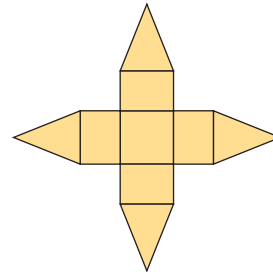

- Draw a net for each object. Identify and name each face.

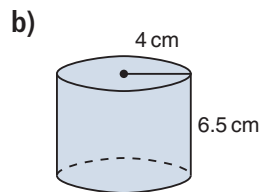
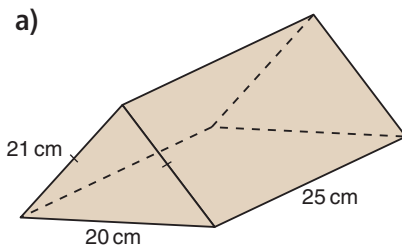

- Which diagrams are nets of a cylinder? How do you know?

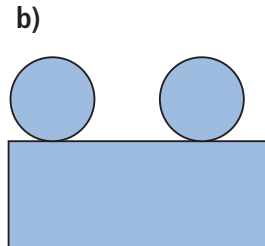
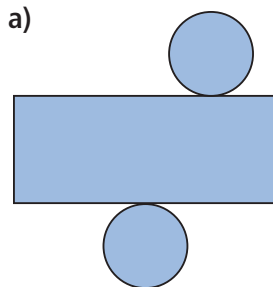

- Here are the nets of a rectangular prism, a triangular prism, and a cylinder. What is the surface area of each object?

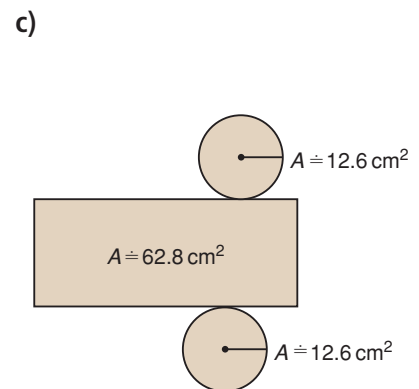
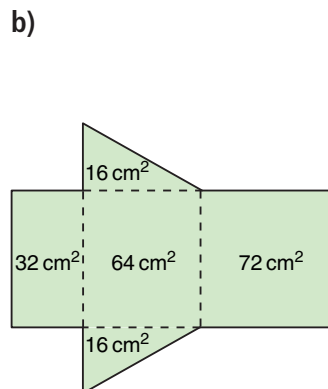
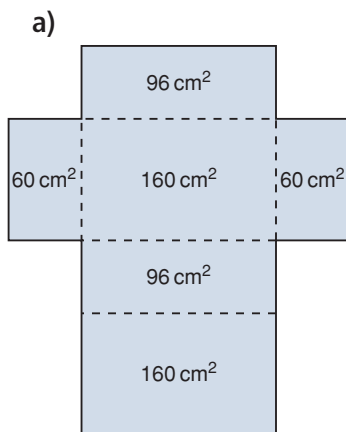

5. The base area and height of each prism are given.
Calculate the volume of each prism.

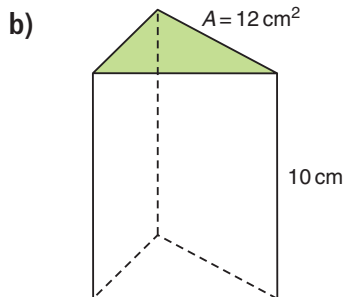
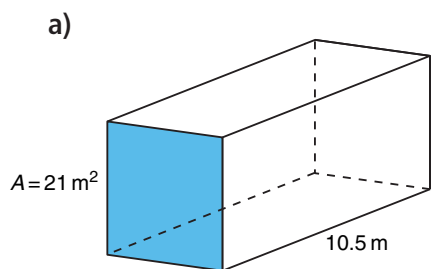

6. Find the surface area and volume of each prism.

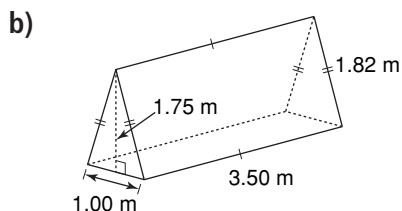
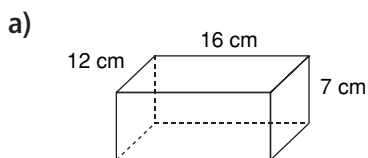

7. Find the volume of each cylinder.

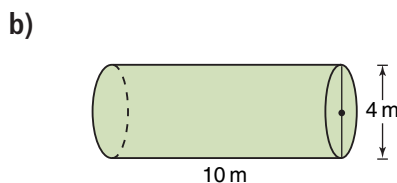
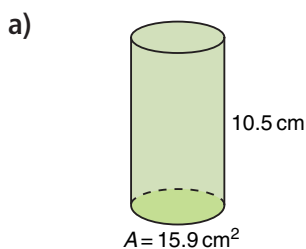

8. Look at the triangular prism in question 6.
Suppose the base and height of the triangular faces are tripled.
- How does this affect the volume of the prism? Explain.
 - Sketch the larger prism.
 - Calculate the volume of the larger prism.
9. The dimensions of a wooden sandbox for a local playground are 2 m by 3 m by 25 cm. The sandbox is a rectangular prism.
- Calculate the area of wood needed to build the sandbox.
 - Calculate the volume of sand it will hold.
10. Which has the greater volume?
- a piece of paper rolled into a cylinder lengthwise, or
 - the same piece of paper rolled into a cylinder widthwise
- Justify your answer. Include diagrams in your answer.

Here are some structures that represent the prisms studied in this unit.

Chan Centre,
Vancouver



Winnipeg
Art Gallery



Husky Oil Building,
Calgary



A *diorama* uses objects to create a landscape or a cityscape against a realistic background.

Your task is to create your own cityscape to resemble part of the downtown core of a major city.

Part A

Plan your diorama on grid paper.

Your design must include at least:

- 1 rectangular prism
- 1 triangular prism
- 1 cylinder
- 1 different prism (hexagonal, pentagonal, and so on)
- 1 water storage facility, such as a reservoir, water tank, swimming pool, and so on.

Record the dimensions of each prism you use.

Check List

Your work should show:

- ✓ a plan of your diorama on grid paper
- ✓ a model of your plan
- ✓ each painted surface area and the volume of water
- ✓ detailed and accurate calculations

Part B

Build a model of your diorama.

Use any materials available: cardboard tubes, boxes, plastic objects, coloured pencils, coloured paper, paint, and so on.

Make your model appealing.



Part C

Each object in your diorama will be painted.

You must order the correct amount of each colour of paint.

To do this, you need to know the area of each surface that is to be painted.

Calculate each surface area.

Assume each water storage facility is full.

Calculate the volume of water in your diorama.

Reflect on Your Learning

How are the volumes of prisms and cylinders related?

How can you use nets to calculate surface areas?

Investigation

Pack It Up!

Work with a partner.

Imagine that you work for a packaging company. You have a sheet of thin card that measures 28 cm by 43 cm. You use the card to make a triangular prism with the greatest volume. The triangular faces of the prism are right isosceles triangles. As you complete this *Investigation*, include all your work in a report that you will hand in.

Materials:

- sheets of paper measuring 28 cm by 43 cm
- piece of thin card measuring 28 cm by 43 cm
- centimetre ruler
- 0.5-cm grid paper
- scissors
- tape

Part 1

Here is one prism and its net.

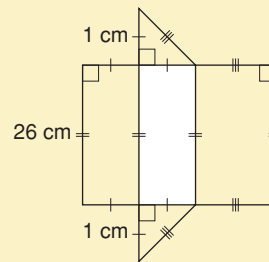
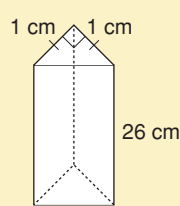

These pictures are *not* drawn to scale.

Each triangular face of this prism has base and height 1 cm. Increase the base and height of the triangular faces by 1 cm each time.

Calculate the length of the prism and its volume.

Copy and complete this table.

Triangular Face			Length of Prism (cm)	Volume of Prism (cm ³)
Base (cm)	Height (cm)	Area (cm ²)		
1	1			
2	2			

Continue to increase the base and height of the triangular face. Use a sheet of paper to draw each net if you need to. The length of the prism decreases each time, so the net always fits on the piece of paper.

- When do you know that the table is complete?
- What patterns do you see in the table? Explain.
- From the table, what is the greatest volume of the prism? What are its dimensions?

Part 2

Use 0.5-cm grid paper.

Draw a graph of *Volume* against *Base of triangular face*.

- What inferences can you make from the graph?
- How can you find the greatest volume from the graph?



Part 3

Use a piece of thin card that measures 28 cm by 43 cm. Construct the net for your prism. Cut out, then fold and tape the net to make the prism.

Take It Further

Does the prism with the greatest volume also have the greatest surface area? Write about what you find out.